

H901 High performance current vector inverter

(User's Guide)



Please Read This Manual Carefully Berfore Using

Contents

Chapter One Security Information	1
1.1 Symbols and definitions of safety information	1
1.2 Scope of use	2
1.3 Installation environment	3
1.4 Installation safety matters	3
1.5 Safety precautions for use	7
Chapter Two Product standard specifications	10
2.1 Technical specification	10
2.2 Inverter model description	14
2.3 Chassis and keyboard dimensions	15
2.4 Product overall dimensions and installation dimensions A (unit : MM)	17
2.5 Braking resistor selection table	18
Chapter Three Storage and installation	20
3.1 Storage	20
3.2 Installation location and environment	20
3.3 Installation space and direction	21
Chapter Four Wiring	22
4.1 Main circuit wiring diagram	22
4.2 Terminal diagram	23
4.2.1 The function description of the main circuit terminals is as follows:	23
4.2.2 Terminals of control circuit	23
4.2.3 Main control board jumper settings	29
4.3 Basic wiring diagram	29
4.4 Wiring precautions	31
4.4.1 Main circuit wiring	31

4.4.2 Control circuit wiring (signal line)	32
4.4.3 Ground wire	32
4.5 Specific application considerations	33
4.5.1 Selection	33
4.5.2 Precautions for using the motor	35
Chapter Five Operation and display	38
5.1 Operation panel description	38
5.1.1 Operation panel icon	38
5.1.2 Button description	39
5.1.3 Function indicator light description	39
5.2 Operation process	40
Chapter Six Function parameter table	42
Chapter Seven EMC (Electromagnetic Compatibility)	109
7.1 Definition	109
7.2 Introduction to EMC standards	109
7.3 EMC guidance	110
Chapter Eight Fault diagnosis and countermeasures	114
8.1 Fault alarm and countermeasures	114
Appendix 1: Modbus communication protocol	124
Appendix 2: Macro parameter setting instructions	136
Appendix 3: Description of three-pump circulating soft water supply parameters	139
Warranty Agreement	152
Warranty Card	153

Chapter One Security Information

1.1 Symbols and definitions of safety information

The safety provisions described in this user manual are very important to ensure that you use the inverter safely to prevent yourself or the people around you from being injured and the property in the working area from being damaged. Please be fully familiar with the following icons and their meanings, and be sure to follow the marked precautions. matter, then continue reading this user manual.



This symbol indicates that failure to operate as required may result in death or serious injury.



This symbol indicates that if operations are not performed as required, It will cause moderate personal injury or minor injury and certain material losses.



This symbol indicates matters that require attention during operation or use.



TIPS

This symbol prompts the user with some useful information.

The following two icons are supplementary explanations of the above signs:



PROHIBIT

Indicates something that must never be done.



FORCE

Indicates something that must be done.

1.2 Scope of use



CAUTION

This frequency converter is suitable for general industrial three-phase AC asynchronous motors.



WARN

- This inverter cannot be used in equipment that may threaten life or harm the human body due to inverter failure or working errors (nuclear power control equipment, aerospace equipment, transportation equipment, life support systems, safety equipment, weapon systems, etc.). If necessary, For special purposes, please consult our company in advance.
- This product is manufactured under the supervision of a strict quality management system, but when used in important equipment, safety protection measures must be taken to prevent the scope of the accident from expanding when the frequency converter fails.

1.3 Installation environment

- Install indoors in a well-ventilated place. Generally, it should be installed vertically to ensure the best cooling effect. For horizontal installation, additional ventilation may be required.
- The ambient temperature is required to be in the range of $-10 \sim 40$ °C. If the temperature exceeds 40 °C, please remove the upper cover. If the temperature exceeds 50 °C, external forced cooling or derating is required. It is recommended that users do not use the inverter in such a high temperature environment, as this will greatly reduce the service life of the inverter.
- Environmental humidity is required to be less than 90% , and there is no condensation of water droplets.
- Install in a place with vibration less than 0.5G to prevent damage from falling. Do not allow the inverter to suffer sudden impacts.
- Install in an environment away from electromagnetic fields and free of flammable and explosive substances.

1.4 Installation safety matters



- Do not use wet hands for work.
- It is strictly prohibited to perform wiring work without completely disconnecting the power supply.

- When the inverter is powered on and running, please do not open the cover or perform wiring work, otherwise there is a risk of electric shock.
- When performing wiring, inspection, etc., the power must be turned off for 10 minutes, otherwise there is a risk of electric shock.



- Do not install or use an inverter with damaged or missing components to prevent personal accidents and property losses.
- The main circuit terminals and cables must be firmly connected. Otherwise, the inverter may be damaged due to poor contact.
- For safety reasons, the ground terminal of the frequency converter must be reliably grounded . In order to avoid the influence of ground common impedance interference, The grounding of multiple frequency converters should use a point grounding method, as shown in Figure 1-1 .

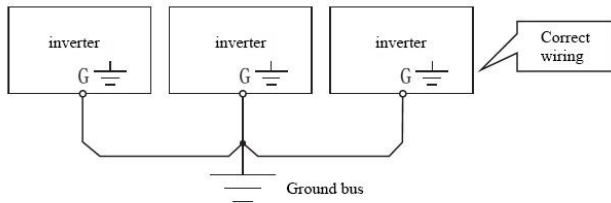

figure 1-1



- It is strictly prohibited to connect the AC power supply to the output terminals U , V , and W of the inverter , otherwise the inverter will be damaged, as shown in Figure 1-2 .

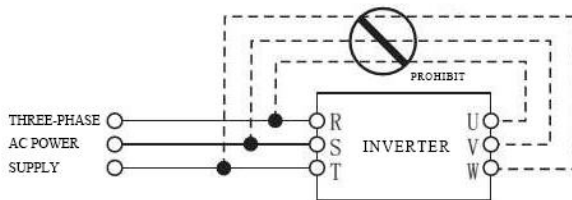

figure 1-2



FORCE

- Be sure to configure a no-fuse circuit breaker for circuit protection on the input power side of the inverter to prevent the expansion of accidents caused by inverter failure.



CAUTION

- It is not suitable to install an electromagnetic contactor on the output side of the frequency converter. This is because when the contactor is turned on and off when the motor is running, operating overvoltage will occur and

cause damage to the inverter. However, configuration is still necessary for the following three situations:

For frequency converters used for energy-saving control, the system always operates at the rated speed. In order to achieve economical operation, the frequency converter needs to be cut off.

When participating in important process flows, which cannot be shut down for a long time, and need to switch between various control systems to improve system reliability.

When one frequency converter controls multiple motors. Users should note that the contactor must not operate when the inverter has output!

1.5 Safety precautions for use



- Do not operate with wet hands.
- For inverters that have been stored for more than 1 year, the voltage should be gradually increased to the rated value using a voltage regulator when powering on, otherwise there is a risk of electric shock and explosion.
- Do not touch the inside of the inverter after powering on. Do not put rods or other objects into the inverter, otherwise it may cause electric shock or the inverter may not work properly.
- Do not open the cover while the inverter is powered on. Otherwise there is a risk of electric shock.
- Use the restart function after power outage with caution, otherwise it may cause personal injury or death.



- If the operation exceeds 50Hz, the speed range of the motor bearings and mechanical devices must be ensured.
- Mechanical devices that require lubrication such as reduction boxes and gears should not be operated at low

speed for a long time, otherwise their service life will be reduced or even the equipment will be damaged.

- When ordinary motors run at low frequencies, the heat dissipation effect becomes poor and must be derated. If the motor is a constant torque load, the motor must be forced to dissipate heat or use a special frequency conversion motor.

- If the inverter is not used for a long time, be sure to cut off the input power to avoid damage to the inverter or even fire caused by foreign matter entering or other reasons.

- Since the output voltage of the inverter is a PWM pulse wave, please do not install a capacitor or surge current absorber (such as a varistor) at its output end, otherwise it will cause the inverter to malfunction and trip, or even damage the power components. . If it has been installed, be sure to remove it. See Figure 1-3 .

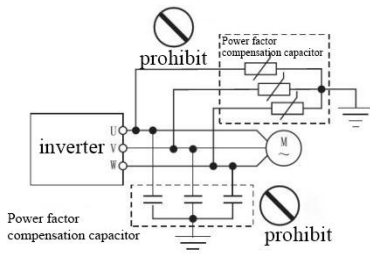

figure 1-3



CAUTION

- Before using the motor for the first time or reusing it after being left for a long time, the motor insulation

should be checked and ensure that the measured insulation resistance is not less than $5M\Omega$.

- If you need to use the frequency converter outside the allowable operating voltage range, you need to configure a voltage boost or step-down device for voltage transformation.
- In areas with an altitude of more than 1,000 meters, due to the thin air, the heat dissipation effect of the inverter will become worse. At this time, it needs to be derated. Generally, the derating needs to be derated by about 10% for every 1000m of elevation . See Figure 1-4 for the derating curve .

Chapter Two Product standard specifications

2.1 Technical specification

Input	Rated voltage, frequency	Three-phase AC 380V;50/60Hz Single-phase AC 220 V;50/60Hz		
	voltage allowed Range of change	Three-phase AC 3 80 V ~ 4 8 0 V Single-phase AC220 V ~ 2 6 0 V		
Output	Voltage	0 ~ 480V 0 ~ 260V		
	Frequency	Vector control: 0~500Hz V/F control: 0~5000Hz		
	Overload capacity	G type machine: 150% rated current for 60s; 180% rated current for 3s. P type machine: 120% rated current for 60s; 150% rated current for 3s.		
Control method		V/F control, speed sensorless vector control (SVC)		
Control characteristics	Frequency setting resolution	Analog input	Maximum frequency×0.025%	
		Digital settings	0.01Hz	
	V/F control	V/F curve	Three methods: linear type; multi-point type; N-th power V/F curve (1.2 power, 1.4 power, 1.6 power, 1.8 power, 2 power)	
		V/F separation	2 ways: full separation, semi-separation	
	Torque boost	Manual setting: 0.0~30.0% of rated output Automatic lifting: automatically determine the lifting		

			torque according to the output current and combined with the motor parameters
		Automatic current limiting and pressure limiting	Whether during acceleration, deceleration or stable operation, it can automatically detect the motor stator current and voltage, and suppress it within the allowable range based on a unique algorithm to minimize the possibility of system fault tripping.
Control characteristics	Inductive vector control	Voltage frequency characteristics	Automatically adjust the output voltage-to-frequency ratio based on motor parameters and unique algorithm
		Torque characteristics	Starting torque: 150% rated torque at 3.0Hz (V/F control) 150% rated torque at 0.5Hz (vector control without speed sensor) Operating speed steady-state accuracy: $\leq \pm 0.2\%$ rated synchronous speed Speed fluctuation: $\leq \pm 0.5\%$ rated synchronous speed Torque response: $\leq 20\text{ms}$ (vector control without speed sensor)
		Self-determination of motor parameters	Without any restrictions, automatic parameter detection can be completed under both static and dynamic conditions of the motor to obtain the best control effect.
		Current and voltage suppression	Full current closed-loop control, completely avoiding current impact, with complete overcurrent and overvoltage suppression functions
	Undervoltage suppression during	Especially for users with low grid voltage and frequent fluctuations in grid voltage, even if the voltage is lower than the allowed voltage range, the system can maintain the longest possible operating time based on a unique algorithm and residual energy allocation strategy.	

	operation			
Typical functions	Multi-speed and swing frequency operation		16-segment programmable multi-segment speed control, multiple operating modes available. Swing frequency operation: preset frequency and center frequency are adjustable, state memory and recovery after power outage	
	PID control RS485 communication		Built-in PID controller (frequency can be preset), standard configuration RS485 communication function	
	Frequency setting	Analog input	DC voltage 0~10V, DC current 0~20mA (upper and lower limits optional)	
		digital input	Operation panel setting, RS485 interface setting, UP/DOWN terminal control, and various combination settings with analog input	
	output signal	digital output	2 Y terminal open collector outputs and 2 programmable relay outputs (TA, TB, TC), up to 58 meaning options	
		Analog output	2 analog signal outputs, the output range can be flexibly set between 0~20mA or 0~10V, which can realize the output of physical quantities such as set frequency and output frequency.	
	Automatic voltage stabilization operation		You can choose dynamic voltage stabilization, static voltage stabilization, or unstabilized voltage according to your needs to obtain the most stable operating effect.	
	Acceleration and deceleration time setting		0.0s~6500.0s can be set continuously, S-shaped and linear modes are optional	
	brake	Energy	Energy consumption braking starting voltage, hysteresis voltage and	

		consumption brake	energy consumption braking rate are continuously adjustable
		DC brake	Stop DC braking starting frequency: 0.00~[F00.10] maximum frequency Braking time: 0.0~100.0s; Braking current: 0%~100% rated current
	Low noise operation	The carrier frequency is continuously adjustable from 0.5KHz to 16.0KHz to minimize motor noise.	
	RPM tracking speed restart function	It can realize smooth restart and instantaneous stop restart function of the running motor.	
	counter	An internal counter to facilitate system integration	
	run function	Upper and lower limit frequency settings, frequency jump operation, reverse operation limit, slip frequency compensation, RS485 communication, frequency increase and decrease control, fault self-recovery operation, etc.	
Display	Operation panel display	run state	Output frequency, output current, output voltage, motor speed, set frequency, module temperature, PID setting, feedback amount, analog input and output, etc.
		Alarm content	There are 8 operating parameter records including output frequency, set frequency, output current, output voltage, DC voltage, module temperature, power-on time, and running time when three faults trip.
Protective function			Overcurrent, overvoltage, undervoltage, module failure, electronic thermal relay, overheating, short circuit, input and output phase loss, abnormal motor parameter tuning, internal memory failure, etc.

Environment	ambient temperature	-10°C~+40°C (environment temperature is between 40°C~50°C, please derate for use)
	ambient humidity	5%~95%RH, no water droplets condensation
	surroundings	Indoor (no direct sunlight, no corrosion, flammable gas, oil mist, dust, etc.)
	altitude	Derating for use above 1000 meters, derate by 10% for every 1000 meters.
Structure	Protection level	IP20
	cooling method	Air-cooling, with fan control
Installation method		Wall-mounted; cabinet type

2.2 Inverter model description

Voltage level	Rated power (KW)	Rated output current (A)	Adapted motor (KW)
380V three-phase	0.75	2.5	0.75
	1.5	3.7	1.5
	2.2	5	2.2
	4.0	9	4

	5.5	13	5.5
	7.5	17	7.5
	11	25	11

2.3 Chassis and keyboard dimensions

2.3.1 Keyboard dimensions



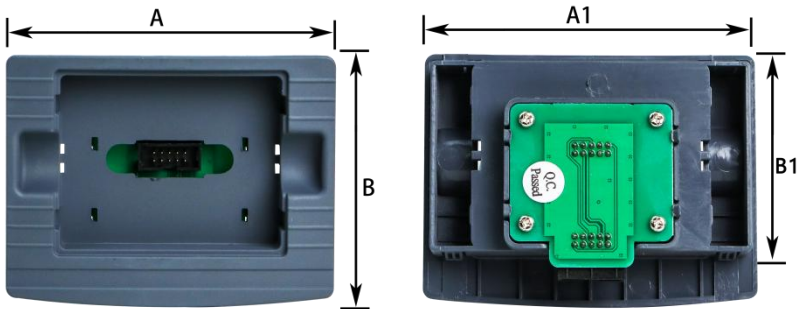

Overall dimensions (mm)		Opening size (mm)	
A	B	A1	B1
105	81	100.5	60

2.4 Product overall dimensions and installation dimensions A (unit : MM)

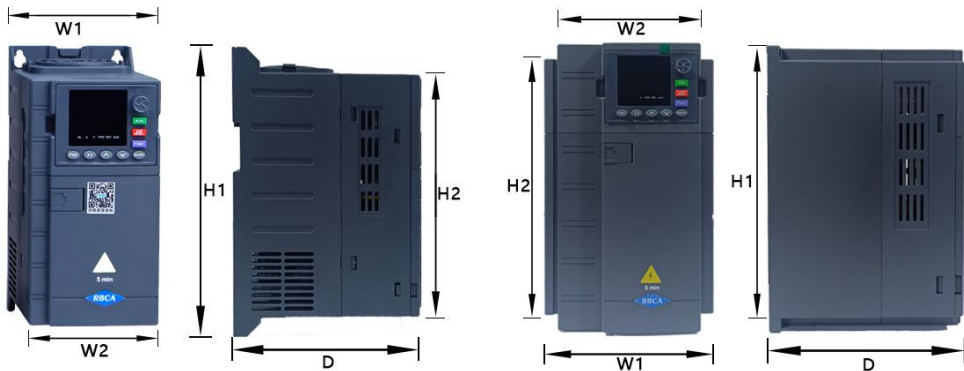

Voltage level	Inverter model	Power (kw)	Overall dimensions (mm)			Installation dimensions (mm)			Packing size (mm)			Net weight (kg)
			W1	H1	D	W2	H2	Φ	long	W	high	
380V three-phase	H901-4T0R75G	0.75	78	170	125	60	161	5	200	115	175	1.06
	H901-4T01R5G	1.5										1.06
	H901-4T02R2G	2.2										1.1
	H901-4T0004G	4	95	210	145	78	198	5	240	130	190	1.88
	H901-4T05R5G	5.5										1.91
	H901-4T07R5G	7.5	140	240	178	130	230	5	280	180	220	3.14
	H901-4T0011G	11										3.36

2. 5 Braking resistor selection table

Voltage (V)	Inverter power (kW)	Braking resistor specifications		braking torque
		W	Ω	10%ED
Single phase 220V	0.4	80	200	125
	0.75	80	150	125
	1.5	100	100	125

Voltage (V)	Inverter power (kW)	Braking resistor specifications		braking torque
		W	Ω	10%ED
	2.2	100	70	125
	4.0	300	50	125
Three-phase 220V	0.75	150	110	125
	1.5	250	100	125
	2.2	300	65	125
	4	400	45	125
	5.5	800	22	125
	7.5	1000	16	125
Three-phase 380V	0.75	100	750	125
	1.5	300	400	125
	2.2	300	250	125
	4	400	150	125
	5.5	500	100	125
	7.5	1000	75	125
	11	3000	43	125

Notice:

1. Please select the resistance value specified by our company.
2. Our company does not bear any responsibility if the inverter or other equipment is damaged due to the use of braking resistors not provided by our company.
3. The installation of the braking resistor must consider the safety and flammability of the environment, and be at least 100mm away from the frequency converter .
4. The parameters in the table are for reference only and do not serve as standards.

Chapter Three Storage and installation

3.1 Storage

This product must be placed in the packaging box before installation. If it is not used temporarily, please pay attention to the following items when storing:

- Must be placed in a dust-free, dry location;
- Storage environment temperature ranges from $-20\text{ }^{\circ}\text{C}$ to $+65\text{ }^{\circ}\text{C}$;
- The relative humidity of the storage environment is within the range of 0% to 95% , and there is no condensation;
 - The storage environment does not contain corrosive gases or liquids;
 - It is best to place it on a shelf and package it for storage. It is best not to store the inverter for a long time. Long-term storage will cause the deterioration of electrolytic capacitors. If long-term storage is required, it must be powered on once every six months for at least 5 hours. During input, the voltage must be slowly increased to the rated voltage using a voltage regulator.

3.2 Installation location and environment

Note: The environmental conditions of the installation site will affect the service life of the inverter. Please install the inverter in the following places:

- Ambient temperature: $-5\text{ }^{\circ}\text{C} \sim 40\text{ }^{\circ}\text{C}$ and good ventilation;
- A place without dripping water and low temperature;
- Places without sunlight, high temperature and heavy dust;
- A place without corrosive gases and liquids;
- A place with less dust, oil, gas and metal dust;

- No vibration, easy maintenance and inspection;
- A place without electromagnetic noise interference;

3.3 Installation space and direction

- For the convenience of maintenance, enough space must be left around the inverter. as the picture shows.
- In order to achieve good cooling effect, the inverter must be installed vertically and ensure smooth air circulation.
 - If the installation is not secure. Place a flat plate under the base of the inverter before installing it. If installed on a loose surface, the stress may cause damage to the main circuit parts, thus damaging the inverter;
 - The installation wall should be made of non-combustible materials such as iron plates.
 - When multiple inverters are installed in the same cabinet, when installing them up and down, pay attention to the spacing and add a flow guide partition in the middle or install them in a staggered position up and down.

Chapter Four Wiring

4.1 Main circuit wiring diagram

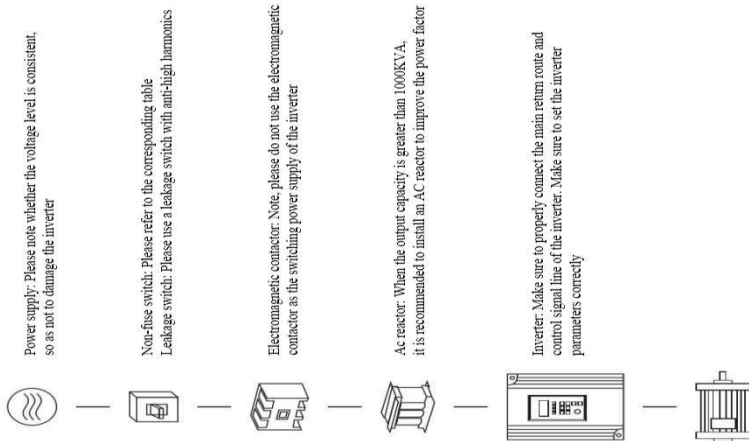

4.2 Terminal diagram

4.2.1 The function description of the main circuit terminals is as follows:

Terminal name	Function description
R、S、T	Three-phase power input terminal
P+、P-	External brake unit reserved terminals
P+、PB	Reserved terminal for external brake resistance
P+、P1	Reserved terminal for external DC reactor
U、V、W	Three-phase AC output terminal
	Ground terminal

4.2.2 Terminals of control circuit

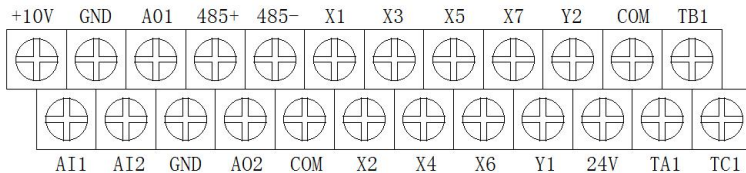

0.75 kw-11kw control loop terminal diagram

Control loop terminal function description

category	Terminal label	Function Description	Specification
Multi-function digital input terminal	X1	Valid when short-circuit between X (X1, X2, X3, X4, X5, X6, X7) and COM. Its functions are set by parameters F07.00~F07.06 respectively (common terminal: COM)	INPUT, 0~24V level signal, active low level, 5mA.
	X2		
	X3		
	X4		
	X5		
	X6		
	X7	In addition to being used as an ordinary multi-function terminal, X7 can also be programmed as a high-speed pulse input port. Please refer to the function description of F07.06 for details.	
Analog input and output terminals	AI1	AI1 receives analog voltage/current input. The voltage and current are selected by jumper JP3. The factory default input	INPUT, input voltage range: 0~10V (input impedance: 100K Ω), input current range:

	AI2	voltage is. If you want to input current, just adjust the jumper cap to the Cin position; AI2 only receives voltage input. For the measurement range setting, please refer to the description of function codes F07.13~F07.22. (Reference ground: GND)	0~20mA (input impedance: 500Ω).
	AO1	AO1 provides analog voltage/current output, which can represent 16 physical quantities. The output voltage and current are selected by jumper JP4. The factory default output voltage is. If you want to output current, just jump the jumper cap to the Co1 position; see for details Description of function codes F08.07 and F08.08. (Reference ground: GND)	OUTPUT, 0~10V DC voltage. The output voltage of the AO1 and AO2 terminals is the PWM waveform from the central processor. The size of the output voltage is proportional to the width of the PWM waveform.
	AO2		
Relay output	TA1	Programmable and defined as multi-functional relay output terminals, up to 44 types. For details, please refer to the introduction of terminal functions of F08.02 and F08.03.	TA1-TB1 and TA2-TB2 are normally closed; TA1-TC1 and TA2-TC2 are normally open. Contact capacity: 250VAC/2A (COSΦ=1); 250VAC/1A (COSΦ=0.4), 30VDC/1A.
	TB1		
	TC1		
	TA2		
	TB2		
	TC2		
digital output	Y1	Open collector output terminals, up to 44	Output voltage range: 0V ~

	Y2	types. For details, please refer to the introduction of terminal functions of F08.04 and F08.05.	24V Output current range: 0mA ~ 50mA
	DO	Programmable pulse signal output terminals defined as multiple functions, up to 16 types. For details, see F08.06 output terminal function introduction. (Common port: COM).	OUTPUT, the output frequency range is set by F08.09 and the maximum frequency can reach 100KHz.
Power interface	+24V	+24V is the circuit common power supply for digital signal input terminals	Maximum output current 200mA
	+10V	+10V is the circuit common power supply for the analog input and output terminals	Maximum output current 20mA
	COM	Digital signal and +24V power reference ground	Internally isolated from GND
	GND	Analog signal and +10V power reference ground	Internally isolated from COM
Communication Interface	485+	RS485 signal + terminal	Standard RS485 communication interface is not isolated from GND, please use twisted pair or shielded wire.
	485-	RS485 signal-terminal	

4. 2.3 Toggle switch and corresponding relationship

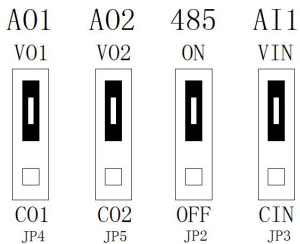

0.75 kW -11 kW toggle switch and corresponding relationship

4.2.3 Main control board jumper settings

JP3	
Cin	Indicates AI1 input current signal
Vin	Indicates AI1 input voltage signal
JP2	
OFF	Indicates matching resistor on the 485 communication is not connected.
ON	Indicates matching resistor access on 485 communication
JP5	
Vo2	Represents Ao2 output voltage signal
Co2	Represents Ao2 output current signal
JP4	
Vo1	Represents Ao1 output voltage signal
Co1	Represents Ao1 output current signal

0.75 kW -11 kW toggle switch and corresponding relationship

4.3 Basic wiring diagram

The wiring part of the frequency converter is divided into main loop and control loop. The user can lift the cover of the casing, and the main circuit terminals and control circuit terminals can be seen. The user must connect them accurately according to the following wiring circuits.

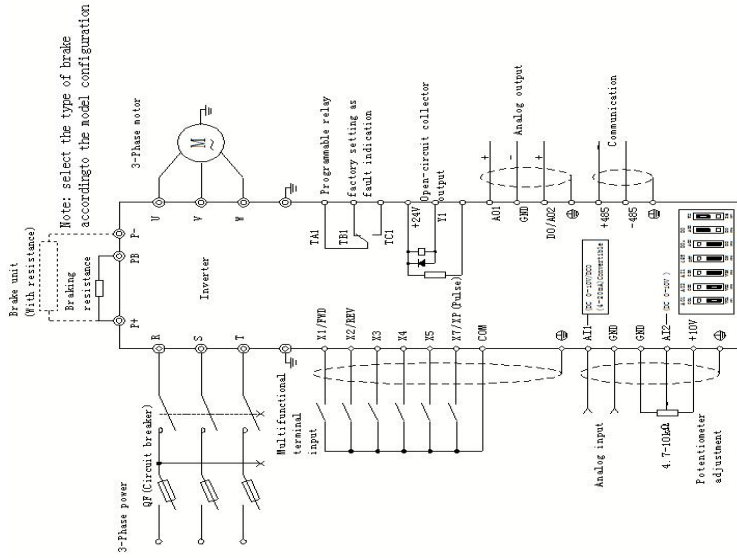

Note: select the type of brake according to the model configuration

Basic operation wiring diagram

4.4 Wiring precautions

4.4.1 Main circuit wiring

- When wiring, please select wiring diameter specifications in accordance with electrical regulations to ensure safety.
- It is best to use isolated wires or conduits for power supply wiring, and ground both ends of the isolation layer or conduits;
 - Be sure to install an air breaker NPB between the power supply and input terminals (R , S , T) . (When using a leakage circuit breaker, please use a circuit breaker with high frequency countermeasures) .
 - Power lines and control lines should be arranged separately and not in the same wire trough.
 - Do not connect the AC power supply to the output terminals (U , V , W) of the inverter ;
 - The output wiring must not touch the metal part of the inverter shell, otherwise it may cause a short circuit to ground.
- Phase-shifting capacitors, LC , RC noise filters and other components cannot be used at the output end of the frequency converter.
 - The main circuit wiring of the frequency converter must be kept away from other control equipment.

-
- When the wiring between the inverter and the motor exceeds 50 meters (220V series) , (380V class 100 meters) , a high dv/dt will be generated inside the motor coil , which will cause damage to the motor's interlayer insulation. If it is damaged, please use an AC motor dedicated to the inverter or install a reactor on the inverter side.
 - When the distance between the inverter and the motor is long, please reduce the carrier frequency, because the larger the carrier, the greater the high-order harmonic leakage current on the cable, and the leakage current will have adverse effects on the inverter and other equipment.

4.4.2 Control circuit wiring (signal line)

Signal wires cannot be placed in the same wire trough as the main circuit wiring, otherwise interference may occur. Please use shielded wires for signal lines and ground them at one end. The wire diameter is 0.5-2mm² . It is recommended to use 1 shielded wire for control lines. Use the control terminals on the control panel correctly as needed.

4.4.3 Ground wire

Ground wire terminal E should be grounded in the third grounding method (below 100 Ω) . When using the ground wire, please follow the basic length and size of electrical equipment technology. Absolutely avoid sharing ground electrodes with large power equipment such as welding machines and power machinery. The grounding wire should be kept as far away from the power lines of large electrical equipment as possible; for the grounding wiring of multiple inverters, please use the following figure (a) to avoid causing loops (b) or (c) .

- Ground wiring must be as short as possible.
- Ground terminal E must be properly grounded and must not be connected to the neutral line.

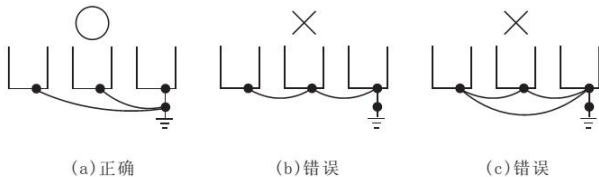

4.5 Specific application considerations

4.5.1 Selection

(1) Installation of reactor

the inverter is connected to a large-capacity power transformer (above 600kVA) or the phase advance capacitor is switched, the power input circuit will generate excessive peak current, which may damage the components of the converter. To prevent this from happening, install a DC reactor or AC reactor. This also helps improve the power factor on the mains side. In addition, when a thyristor converter such as a DC driver is connected to the same power supply system, a DC reactor or AC reactor must be installed regardless of the power supply conditions.

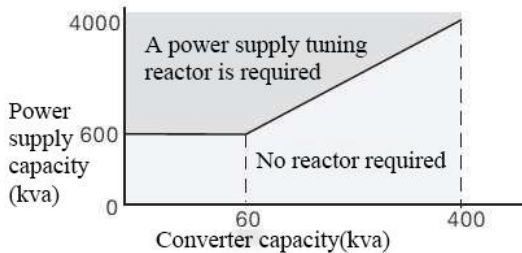

Reactor installation conditions

(2) Inverter capacity

When running a special motor, please confirm that the rated current of the motor is not higher than the rated output current of the inverter. In addition, when multiple induction motors are operated in parallel with one inverter, the capacity of the inverter should be selected so that 1.1 times the total rated current of the motor is less than the rated output current of the inverter.

(3) Starting torque

The starting and acceleration characteristics of a motor driven by an inverter are limited by the overload rated current of the combined inverter. Compared with the starting of general commercial power supply, the torque characteristics are smaller. If a larger starting torque is required, please increase the capacity of the inverter by one level or increase the capacities of the motor and the inverter at the same time.

(4) Emergency stop

Although the protection function will operate and the output will stop when the inverter fails, the motor cannot be stopped suddenly at this time. Therefore, please install a mechanical stopping and holding structure on mechanical equipment that requires emergency stop.

(5) Special options

Terminals PB(+) and P1(+) are terminals for connecting dedicated options. Do not connect to equipment other than dedicated options.

(6) Precautions related to reciprocating loads

150% or more exceeds this value is repeatedly passed through, the IGBT inside the inverter will shorten its service life due to thermal fatigue. As a rough guide, when the carrier frequency is 4kHz and the peak current is 150%, the number of starts / stops is approximately 8 million.

Especially when low noise is not required, please lower the carrier frequency. In addition, please reduce the peak current during reciprocation to less than 150% by reducing the load, extending the acceleration and deceleration time, or increasing the inverter capacity by one level. (When performing test runs for these applications, be sure to confirm the reciprocating current. peak current and adjust as needed). In addition, when used in cranes, since the start / stop action during inching is fast, it is recommended to make the following selections to ensure the motor torque and reduce the current of the inverter. · The capacity of the frequency converter should ensure that its peak current is less than 150%. The capacity of the frequency converter should be at least 1 level larger than the motor capacity.

4.5.2 Precautions for using the motor

(1) For use with existing standard motors

low speed domain

Compared with using a commercial power supply to drive a standard motor using an inverter, the losses generated will increase somewhat. In the low speed range, the cooling effect will become worse and the temperature of the motor will increase. Therefore, in the low speed range, please reduce the load torque of the

motor. The allowable load characteristics of our company's standard motors are as shown in the figure. In addition, if 100% continuous torque is required in the low speed range, please consider whether to use a dedicated motor for an inverter.

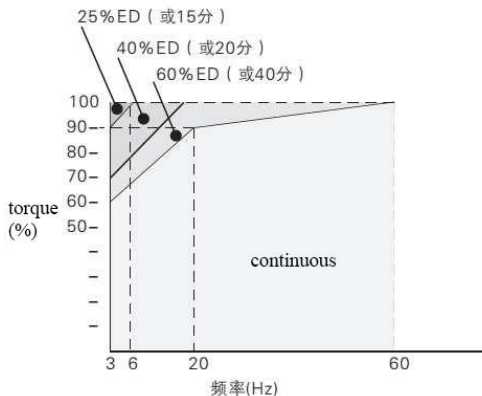

Allowable load characteristics of our standard motor

(2) Precautions when using special motors

Pole-changing motor The rated current of the pole-changing motor is different from the standard motor. Please confirm the maximum current of the motor and select the corresponding inverter. Be sure to switch the pole number

after the motor stops. If switching is performed while rotating, the regenerative overvoltage or overcurrent protection circuit will operate and the motor will coast to a stop.

motor with brake

When using an inverter to drive a motor with a brake, if the brake circuit is directly connected to the output side of the inverter, the brake will not be able to open due to the low voltage at startup. Please use a motor with a brake that has an independent brake power supply, and connect the brake power supply to the power supply side of the inverter. Generally, when using a motor with a brake, the noise may become louder in the low speed range.

(3) Power transmission structure (reducer, belt, chain, etc.)

When using oil-lubricated gearboxes, transmissions, reducers, etc. in the power transmission system, please note that the oil lubrication effect will deteriorate if the oil lubrication system is continuously operated only in the low speed range. In addition, when performing high-speed operation above 60Hz, problems may arise in terms of noise, lifespan, and strength due to centrifugal force of the power transmission structure, so please pay full attention to it .

Chapter Five Operation and display

5.1 Operation panel description

5.1.1 Operation panel icon



5.1.2 Button description

key symbol	name	Function Description
PRG	Programming keys	Menu entry or exit, parameter modification
ENTER	Confirm key	Enter the menu and confirm parameter settings
▲	increment key	Increment of data or function code
▼	Decrement key	Decrement of data or function code
▶▶	Shift key	Select parameter modification bits and display content
RUN	Run key	Run operations in keyboard operation mode
STOP/RESET	Stop/reset button	Stop/reset operation
FUNC	Multifunctional shortcut keys	Switch selection based on function

5.1.3 Function indicator light description

Indicator name	illustrate
REV	The reverse rotation indicator light of the frequency converter indicates the reverse running status when the light is on.
FWD	The frequency converter forward rotation indicator light, when the light is on, indicates the forward rotation running status.
ALM	If the indicator light is always on, it means it is in the torque control state. If it flashes quickly, it means it is in a fault state. If it flashes slowly, it means it is in the tuning state.
Hz	frequency unit
A	Current unit
V	voltage unit

5.1.4 Function indicator light combination description :

Indicator light combination	LED display meaning	symbol
H z + A	Motor speed	r/min
A + V	time (seconds)	s
H z + V	percent actual value	%
H z + A + V	temperature	°C

5.2 Operation process

5.2.1 Parameter settings

The three-level menus are:

1. Function code group number (first-level menu);
2. Function code label (secondary menu);
3. Function code setting value (third-level menu).

Note: When operating in the third-level menu, you can press PRG or ENTER to return to the second-level menu. The difference between the two is: press ENTER to store the set parameters in the control panel, then return to the secondary menu, and automatically transfer to the next function code; press PRG to directly return to the secondary menu, without storing the parameters, and remain in the Current function code.

In the third-level menu state, if the parameter does not flash, it means that the function code cannot be modified. The possible reasons are:

1) This function code is an unmodifiable parameter. Such as actual detection parameters, operation record parameters, etc.

2) This function code cannot be modified during operation and must be shut down before modification can be made.

5.2.2 Fault reset

After the frequency converter fails, the frequency converter will prompt relevant fault information. The user can reset the fault through the STOP/RESET key on the keyboard or the terminal function. After the inverter is reset, it will be in standby mode. If the frequency converter is in a fault state and the user does not reset the fault, the frequency converter is in a running protection state and the frequency converter cannot operate.

5.2.3 Motor parameter self-learning

Select the vector control operation mode . Before running the inverter, you must accurately input the nameplate parameters of the motor. The inverter will This nameplate parameter matches the standard motor parameter; the vector control method is highly dependent on the motor parameters. To obtain good control performance, The accurate parameters of the controlled motor must be obtained.

Chapter Six Function parameter table

When F15.00 is set to a non-0 value, the parameter protection password is set. In the function parameter mode and user change parameter mode, the parameter menu must be entered correctly before the password can be entered. To cancel the password, F15.00 needs to be set to 0. The parameter menu in user-defined parameter mode is not password protected.

The symbols in the function table are explained as follows:

“☆”: Indicates that the setting value of this parameter can be changed when the inverter is in shutdown or running state;

“★”: Indicates that the setting value of this parameter cannot be changed when the inverter is running;

“●”: Indicates that the value of this parameter is the actual detection record value and cannot be changed;

"*": Indicates that the parameter is a "manufacturer parameter", which is limited to the manufacturer's settings and is prohibited from being operated by the user.

F00 basic function group				
function code	name	Predetermined area	Factory default	Change

F00.00	Function macro definition	<p>0: Universal mode 1: (1 variable frequency pump + 2 industrial frequency pumps) water supply mode 1</p> <p>2: Three pump circulation soft start (3 variable frequency pumps) water supply mode</p> <p>3: One variable frequency pump and three industrial frequency pumps Water supply mode</p> <p>4: One variable frequency pump + two industrial frequency pumps Water supply mode 2</p> <p>5: One variable frequency pump + 1 industrial frequency pump) water supply Mode</p> <p>6: Single pump water supply (1 variable frequency pump) Mode</p> <p>7: PV water supply voltage tracking Mode</p>	0	★
--------	---------------------------	---	---	---

		8: PV water supply power tracking VF mode 9: PV water supply power tracking SVC mode 10~100: Reserved Note :Initialize parameters first, then set macros Function.		
F00.01	Motor control method	0: V/F control 1: Speed sensorless vector control (SVC)	0	★
F00.02	Command source selection	0: Operation panel command channel 1: Terminal command channel 2: Communication command channel	0	☆

F00.03	Main frequency source A selection	<p>0: Digital setting (preset frequency F00.08, UP/DOWN can be modified, and will not be remembered after power failure)</p> <p>1: Digital setting (preset frequency F00.08, UP/DOWN can be modified, and will be remembered after power failure)</p> <p>2: AI1 (0~10V/20mA)</p> <p>3: AI2 (0~10V)</p> <p>4: Panel potentiometer</p> <p>5: PULSE pulse setting (X7)</p> <p>6: Multi-segment instruction</p> <p>7: Simple PLC</p> <p>8: PID</p> <p>9: Communication reference</p> <p>10: Multi-pump instruction</p> <p>11: MPPT given (photovoltaic water supply)</p>	4	★
F00.04	Auxiliary frequency source B selection	Same as F00.03 (main frequency source A selection)	0	★
F00.05	Auxiliary frequency source B range selection during superposition	<p>0: relative to the maximum frequency</p> <p>1: relative to frequency source A</p>	0	☆
F00.06	Auxiliary frequency source B range during superposition	0%~150%	100%	☆

F00.07	Frequency source B superposition selection	<p>Units digit: Frequency source selection</p> <p>0: Main frequency source A</p> <p>1: Main and auxiliary operation results (the operation relationship is determined by the tens digit)</p> <p>2: Switching between main frequency source A and auxiliary frequency source B</p> <p>3: Switching between main frequency source A and main and auxiliary operation results</p> <p>4: Switching between auxiliary frequency source B and main and auxiliary operation results.</p> <p>Tens digit: main and auxiliary operation relationship of frequency source</p> <p>0: main + auxiliary</p> <p>1: main - auxiliary</p> <p>2: maximum value of both</p> <p>3: minimum value of both</p>	OO	☆
F00.08	Preset frequency	0.00Hz~maximum frequency (F00.10)	50.00Hz	☆
F00.09	Running direction	<p>0: Same direction</p> <p>1: Opposite direction</p>	0	☆
F00.10	maximum frequency	50.00Hz ~ 50 0.00Hz	50.00Hz	★

F00.11	upper limit frequency source	0: F00.12 setting 1: AI1 2: AI2 3: Panel potentiometer 4: PULSE pulse setting 5: Communication reference	0	★
F00.12	upper limit frequency	Lower limit frequency F00.14 ~ maximum frequency F00.10	50.00Hz	☆
F00.13	Upper limit frequency offset	0.00Hz ~ maximum frequency F00.10	0.00Hz	☆
F00.14	lower limit frequency	0.00Hz ~ upper limit frequency F00.12	0.00Hz	☆
F00.15	carrier frequency	0.5kHz~16.0kHz	Model confirmed	☆
F00.16	Carrier frequency adjusts with temperature	0: No 1: Yes	1	☆
F00.17	Acceleration time 1	0.00s ~ 650.00s(F00.19=2) 0.0s ~ 6500.0s(F00.19=1) 0s ~ 65000s(F00.19=0)	Model confirmed	☆
F00.18	Deceleration time 1	0.00s ~ 650.00s(F00.19=2) 0.0s ~ 6500.0s(F00.19=1) 0s ~ 65000s(F00.19=0)	Model confirmed	☆

F00.19	Acceleration and deceleration time unit	0: 1 second 1: 0.1 second 2: 0.01 second	1	★
F00.21	Auxiliary frequency source offset frequency during superposition	0.00Hz ~ maximum frequency F00.10	0.00Hz	☆
F00.22	Frequency command resolution	1: 0.1Hz 2: 0.01Hz	2	★
F00.23	Digital setting frequency shutdown memory selection	0: Not memorized 1: Memorized	0	☆
F00.24	reserve	—	0	★
F00.25	Acceleration and deceleration time base frequency	0: Maximum frequency (F00.10) 1: Setting frequency 2: 100Hz	0	★
F00.26	Runtime frequency command UP/DOWN benchmark	0: Operating frequency 1: Setting frequency	0	★

F00.27	Command source bundled frequency source	Units digit: Operation panel command binding frequency source selection 0: No binding 1: Digital setting frequency 2: AI1 3: AI2 4: Panel potentiometer 5: PULSE pulse setting (X7) 6: Multi-step speed 7: Simple PLC 8: PID 9: Communication given tens digit: Terminal command binding frequency source selection hundreds digit: Communication command binding frequency source selection thousands digit: Automatic operation binding frequency source selection	0000	☆
F00.28	Serial communication protocol selection	0: Modbus protocol 1 : Reserved	0	☆
F00.29	GP type display	1: G type (constant torque load model) 2: P type (fan, water pump type load model)	Model confirmed	●
F01 group start and stop control				
function code	name	Predetermined area	Factory default	Change

F01.00	Start mode	0: Direct start 1: Speed tracking and restart 2: Pre-excitation start (AC asynchronous machine) 3: Super fast start (valid in vector mode)	0	☆
F01.01	Speed tracking method	0: Start from stop frequency 1: Start from zero speed 2: Start from maximum frequency	0	★
F01.02	Speed tracking speed	1~100	20	☆
F01.03	Start frequency	0.00Hz ~ 10.00Hz	0.00Hz	☆
F01.04	Start frequency hold time	0.0s~100.0s	0.0s	★
F01.05	Starting DC braking current/pre-excitation current	0%~100%	50%	★
F01.06	Start DC braking time/pre-excitation time	0.0s~100.0s	0.0s	★
F01.07	Acceleration and deceleration mode	0: Linear acceleration and deceleration 1: S-curve acceleration and deceleration A 2: S-curve acceleration and deceleration B	0	★
F01.08	The proportion of time at the beginning of the S-curve	0.0% ~ (100.0%-F01.09)	30.0%	★
F01.09	S-curve end time ratio	0.0% ~ (100.0%-F01.08)	30.0%	★

F01.10	shutdown mode	0: Deceleration to stop 1: Free stop	0	☆
F01.11	Stop DC braking starting frequency	0.00Hz ~ maximum frequency	0.00Hz	☆
F01.12	Stop DC braking waiting time	0.0s~100.0s	0.0s	☆
F01.13	Stop DC braking current	0%~100%	50 %	☆
F01.14	Shutdown DC braking time	0.0s~100.0s	0.0s	☆
F01.15	brake usage	0%~100%	100%	☆
F01.16 ~ F01.20	reserve	—	0	☆
F01.21	Speed tracking delay	0.00~5.00s	0.50s	☆
F02 group auxiliary function				
function code	name	Predetermined area	Factory default	Change
F02.00	Jogging operating frequency	0.00Hz ~ maximum frequency	2.00Hz	☆
F02.01	Jog acceleration time	0.0s~6500.0s	20.0s	☆
F02.02	Jog deceleration time	0.0s~6500.0s	20.0s	☆
F02.03	Acceleration time 2	0.0s~6500.0s	Model	☆

			confirmed	
F02.04	Deceleration time 2	0.0s~6500.0s	Model confirmed	☆
F02.05	Acceleration time 3	0.0s~6500.0s	Model confirmed	☆
F02.06	Deceleration time 3	0.0s~6500.0s	Model confirmed	☆
F02.07	Acceleration time 4	0.0s~6500.0s	Model confirmed	☆
F02.08	Deceleration time 4	0.0s~6500.0s	Model confirmed	☆
F02.09	Jump frequency 1	0.00Hz ~ maximum frequency	0.00Hz	☆
F02.10	Jump frequency 2	0.00Hz ~ maximum frequency	0.00Hz	☆
F02.11	Jump frequency amplitude	0.00Hz ~ maximum frequency	0.01Hz	☆
F02.12	Forward and reverse dead time	0.0s~3000.0s	0.0s	☆
F02.13	Reverse frequency prohibited	0: invalid 1: valid	0	☆
F02.14	The set frequency is lower than the lower limit frequency operation mode	0: Run at the lower frequency limit 1: Stop 2: Run at zero speed	0	☆
F02.15	sag control	0.00Hz ~ 10.00Hz	0.00Hz	☆

F02.16	Set the cumulative power-on arrival time	0h~65000h	0h	☆
F02.17	Set cumulative running arrival time	0h~65000h	0h	☆
F02.18	Start protection selection	0: Not protected 1: Protected Note: When F02.18=0, the terminal power-on detection running command is valid; when F02.18=1, the terminal power-on detection running command is invalid.	0	☆
F02.19	Frequency detection value (FDT1)	0.00Hz ~ maximum frequency	50.00Hz	☆
F02.20	Frequency detection hysteresis value (FDT1)	0.0% ~ 100.0% (FDT1 level)	5.0%	☆
F02.21	Frequency Arrival (FAR) detection width	0.0% ~ 100.0% (maximum frequency)	0.0%	☆
F02.22	Is the jump frequency valid during acceleration and deceleration?	0: invalid 1: valid	0	☆
F02.23	Acceleration time 1 and acceleration time 2 switch frequency point	0.00Hz ~ maximum frequency	0.00Hz	☆
F02.24	Deceleration time 1 and deceleration time 2 switch frequency point	0.00Hz ~ maximum frequency	0.00Hz	☆
F02.25	Terminal jog priority	0: invalid 1: valid	0	☆

F02.26	Frequency detection value (FDT2)	0.00Hz ~ maximum frequency	50.00Hz	☆
F02.27	Frequency detection hysteresis value (FDT2)	0.0% ~ 100.0% (FDT2 level)	5.0%	☆
F02.28	Arbitrary arrival frequency detection value 1	0.00Hz ~ maximum frequency	50.00Hz	☆
F02.29	Arbitrary arrival frequency detection width 1	0.0% ~ 100.0% (maximum frequency)	0.0%	☆
F02.30	Arbitrary arrival frequency detection value 2	0.00Hz ~ maximum frequency	50.00Hz	☆
F02.31	Up to frequency detection width 2	0.0% ~ 100.0% (maximum frequency)	0	☆
F02.32	Zero current detection level	0.0% ~ 300.0% 100.0% corresponds to the rated current of the motor	5.0%	☆
F02.33	Zero current detection delay time	0.01s~600.00s	0.10s	☆
F02.34	Output current exceeds limit value	0.0% (not detected) 0.1% ~ 300.0% (motor rated current)	200.0%	☆
F02.35	Output current over-limit detection delay time	0.00s~600.00s	0.00s	☆
F02.36	Any arrival current 1	0.0% ~ 300.0% (motor rated current)	100.0%	☆
F02.37	Any reach current 1 width	0.0% ~ 300.0% (motor rated current)	0.0%	☆
F02.38	Arbitrary current 2	0.0% ~ 300.0% (motor rated current)	100.0%	☆

F02.39	Arbitrary current 2 width	0.0% ~ 300.0% (motor rated current)	0.0%	☆
F02.40	Timing function selection	0: invalid 1: valid	0	☆
F02.41	Scheduled running time selection	0: F02.42 setting 1: AI1 2: AI2 3: Panel potentiometer Note: The analog input range corresponds to F02.42	0	☆
F02.42	Scheduled running time	0.0Min ~ 6500.0Min	0.0Min	☆
F02.43	All input voltage protection value lower limit	0.00V ~ F02.44	3.10V	☆
F02.44	All input voltage protection value upper limit	F02.43 ~ 1 1.00V	6.80V	☆
F02.45	The module temperature reaches	0°C ~ 100°C	75°C	☆
F02.46	Cooling fan control	0: The fan runs during operation 1: The fan always runs	0	☆
F02.47	wake frequency	Sleep frequency (F02.49) ~ maximum frequency (F00.10)	0.00Hz	☆
F02.48	Wake-up delay time	0.0s ~ 6500.0s	0.0s	☆
F02.49	sleep frequency	0.00Hz ~ wake-up frequency (F02.47)	0.00Hz	☆
F02.50	sleep delay time	0.0s ~ 6500.0s	0.0s	☆

F02.51	Arrival time setting for this run	0.0 ~ 6500.0 minutes	0.0Min	☆
F02.52	Output power correction coefficient	0.00%~200.0%	100.0%	☆
Group F03 motor parameters				
function code	name	Predetermined area	Factory default	Change
F03.00	Motor type selection	0: Ordinary asynchronous motor 1: Variable frequency asynchronous motor	0	★
F03.01	Motor rated power	0.1kW ~ 1000.0kW	Model confirmed	★
F03.02	Motor rated voltage	1V~2000V	Model confirmed	★
F03.03	Motor rated current	0.01A ~ 655.35A (inverter power <=55kW) 0.1A ~ 6553.5A (inverter power >55kW)	Model confirmed	★
F03.04	Motor rated frequency	0.01Hz ~ maximum frequency	Model confirmed	★
F03.05	Motor rated speed	1rpm~65535rpm	Model confirmed	★
F03.06	Asynchronous motor stator resistance	0.001 Ω ~ 65.535 Ω (inverter power <=55kW) 0.0001 Ω ~ 6.5535 Ω (inverter power >55kW)	tuning parameters	★

F03.07	Asynchronous motor rotor resistance	0.001 Ω ~ 65.535 Ω (inverter power $\leq 55\text{kW}$) 0.0001 Ω ~ 6.5535 Ω (inverter power $> 55\text{kW}$)	tuning parameters	★
F03.08	Asynchronous motor leakage inductance	0.01mH ~ 655.35mH (inverter power $\leq 55\text{kW}$) 0.001mH ~ 65.535mH (inverter power $> 55\text{kW}$)	tuning parameters	★
F03.09	Asynchronous motor mutual inductance	0.1mH ~ 6553.5mH (inverter power $\leq 55\text{kW}$) 0.01mH ~ 655.35mH (inverter power $> 55\text{kW}$)	tuning parameters	★
F03.10	Asynchronous motor no-load current	0.01A ~ F03.03 (inverter power $\leq 55\text{kW}$) 0.1A ~ F03.03 (inverter power $> 55\text{kW}$)	tuning parameters	★
F03.11 ~ F03.36	reserve	—	0	★
F03.27	Tuning selection	0: No operation 1: Static tuning of asynchronous machine 2: Complete tuning of asynchronous machine 3: Static complete parameter	0	★

		identification		
F04 motor vector control parameters				
function code	name	Predetermined area	Factory default	Change
F04.00	Speed loop proportional gain 1	1~100	30	☆
F04.01	Speed loop integration time 1	0.01s~10.00s	0.50s	☆
F04.02	Switching frequency 1	0.00~F04.05	5.00Hz	☆
F04.03	Speed loop proportional gain 2	1~100	20	☆
F04.04	Speed loop integration time 2	0.01s~10.00s	1.00s	☆
F04.05	Switching frequency 2	F04.02 ~ Maximum frequency	10.00Hz	☆
F04.06	Vector control slip gain	50%~200%	100%	☆
F04.07	Speed loop filter time constant	0.000s~0.100s	0.015s	☆
F04.08	Vector control overexcitation gain	0~200	64	☆

F04.09	Torque upper limit source in speed control mode	0: Function code F04.10 setting 1: AI1 2: AI2 3: Panel potentiometer 4 : PULSE Pulse setting 5: Communication reference 6: MIN (AI1, AI2) 7: MAX (AI1, AI2) 1-7 The full scale range of the option corresponds to F04.10	0	☆
F04.10	Digital setting of torque upper limit in speed control mode	0.0%~200.0%	160.0%	☆
F04.13	Excitation adjustment proportional gain	0 ~ 60000	2000	☆
F04.14	Excitation adjustment integral gain	0 ~ 60000	1300	☆
F04.15	Torque adjustment proportional gain	0 ~ 60000	2000	☆
F04.16	Torque adjustment integral gain	0 ~ 60000	1300	☆
F04.17	Speed loop integral separation	0: invalid 1: valid	0	☆
F04.18 ~ F04.20	reserve	—	0	☆

F05group torque control parameters				
function code	name	Predetermined area	Factory default	Change
F05.00	Speed/torque control mode selection	0: Speed control 1: Torque control	0	★
F05.01	Torque setting source selection in torque control mode	0: Digital setting 1 (F05.03) 1: AI1 2: AI2 3: Panel potentiometer 4: PULSE Pulse 5: Communication reference 6: MIN (AI1, AI2) 7: MAX (AI1, AI2) (1- Full scale of 7 options, corresponding to F05.03 digital setting)	0	★
F05.03	Torque digital setting in torque control mode	—200.0%~200.0%	150.0%	☆
F05.05	Torque control forward maximum frequency	0.00Hz ~ maximum frequency	50.00Hz	☆
F05.06	Torque control reverse maximum frequency	0.00Hz ~ maximum frequency	50.00Hz	☆
F05.07	Torque control acceleration time	0.00s ~ 650. 00s	0.00s	☆
F05.08	Torque control deceleration time	0.00s ~ 650. 00s	0.00s	☆

F06 group V/F control parameters				
function code	name	Predetermined area	Factory default	Change
F06.00	VF curve settings	0: Straight line V/F 1: Multi-point V/F 2: Square V/F 3: 1.2 power V/F 4: 1.4 power V/F 5: Reserved 6: 1.6 power V/F 7: Reserved 8 : 1.8th power V/F 9: Reserved 10: VF complete separation mode 11: VF semi-separation mode	0	★
F06.01	Torque boost	0.0%: (automatic torque boost) 0.1% ~ 30.0%	Model confirmed	☆
F06.02	Torque boost cutoff frequency	0.00Hz ~ maximum frequency	50.00Hz	★
F06.03	Multi-point VF frequency point F1	0.00Hz~F06.05	0.00Hz	★
F06.04	Multi-point VF voltage point V1	0.0%~100.0%	0.0%	★

F06.05	Multi-point VF frequency point F2	F06.03~F06.07	0.00Hz	★
F06.06	Multi-point VF voltage point V2	0.0%~100.0%	0.0%	★
F06.07	Multi-point VF frequency point F3	F06.05 ~ motor rated frequency (F03.04)	0.00Hz	★
F06.08	Multi-point VF voltage point V3	0.0%~100.0%	0.0%	★
F06.09	VF slip compensation gain	0.0%~200.0%	0.0%	☆
F06.10	VF overexcitation gain	0~200	64	☆
F06.11	VF oscillation suppression gain	0~100	Model confirmed	☆
F06.13	VF separated voltage source	0: Digital setting (F06.14) 1: AI1 2: AI2 3: Panel potentiometer 4 : PULSE pulse setting (X7) 5: Multi-segment instruction 6: Simple PLC 7: PID 8: Communication reference Note: 100.0% Corresponding motor rated voltage	0	☆

F06.14	VF separated voltage digital setting	0V ~ motor rated voltage	0V	☆
F06.15	VF separation voltage acceleration time	0.0s ~ 1000.0s Note: Indicates the time from 0V to the rated voltage of the motor.	0.0s	☆
F06.16	VF separation voltage deceleration time	0.0s ~ 1000.0s Note: Indicates the time from 0V to the rated voltage of the motor.	0.0s	☆
F06.17	VF separation shutdown mode selection	0: Frequency/voltage decrease to 0 independently 1: Frequency decreases again after voltage decreases to 0	0	☆
F06.18	VF overcurrent stall action current	50~200%	150%	☆
F06.19	VF overcurrent stall enable	0: invalid 1: valid	1	☆
F06.20	VF overpass stall suppression gain	0~100	20	
F06.21	VF double speed overcurrent stall action current compensation coefficient	50~200%	50%	☆
F06.22	VF overvoltage stall action voltage	200.0~ 2000.0	760.0	☆

F06.23	VF overvoltage stall enable	0: invalid 1: valid	1	☆
F06.24	VF overvoltage stall suppression frequency gain	0~100	30	☆
F06.25	VF overvoltage stall suppression voltage gain	0~100	30	☆
F06.26	Overvoltage stall maximum rising limit frequency	0~ 50Hz	5 Hz	☆
F07group input terminal				
function code	name	Predetermined area	Factory default	Change
F07.00	X1 terminal function selection	0: No function 1: Forward running FWD or running command 2: Reverse running REV or forward and reverse running direction (Note: When set to 1 or 2, it needs to be used in conjunction with F07.11, see the function code parameter description for details) 3 : Three-wire operation control	1	★

F07.01	X2 terminal function selection	4: Forward jogging (FJOG) 5: Reverse jogging (RJOG) 6: Terminal UP 7: Terminal DOWN 8: Free stop 9: Fault reset (RESET) 10: Operation pause 11: External fault Normally open input 12: Multi-segment command terminal 1 13: Multi-segment command terminal 2 14: Multi-segment command terminal 3 15: Multi-segment command terminal 4 16: Acceleration and deceleration time selection terminal 1 17: Acceleration and deceleration time selection terminal 2 18: Frequency source switching 19: UP/DOWN setting clear (terminal, keyboard)	2	★
F07.02	X3 terminal function selection	16: Acceleration and deceleration time selection terminal 1 17: Acceleration and deceleration time selection terminal 2 18: Frequency source switching 19: UP/DOWN setting clear (terminal, keyboard)	9	★

F07.03	X4 terminal function selection	20: Control command switching terminal 1 21: Acceleration and deceleration prohibited 22: PID pause 23: PLC status reset 24 : Swing frequency pause 25: Counter input 26: Counter reset 27: Length counting Input 28: Length reset	12	★
F07.04	X5 terminal function selection	29: Torque control disabled 30: PULSE (pulse) frequency input (only valid for X7) 31: Reserved 32: Immediate DC braking 33: External fault normally closed input 34: Frequency modification enabled 35: PID Reverse direction of action	13	★
F07.05	X6 terminal function selection	36: External parking terminal 1 37: Control command switching terminal 2 38: PID integral pause 39: Switching between frequency	0	★

F07.06	X7 terminal function selection	source A and preset frequency 40: Switching between frequency source B and preset frequency 41: Reserved 42: Reserved 43 : PID parameter switching 44: User-defined fault 1 45: User-defined fault 2 46: Speed control/torque control switching 47: Emergency stop 48: External parking terminal 2 49: Deceleration DC braking 50: Clear this running time 51: Two-wire/three-wire switching 52: Reverse prohibited 53: Start/stop 54: Operation allowed 55: Interlock 1 56: Interlock 2 57: Interlock 3 58: PFC start/stop	30	★
F07.07	reserve		0	★
F07.08	reserve		0	★
F07.09	reserve		0	★
F07.10	X filter time	0.000s~1.000s	0.010s	☆
F07.11	Terminal command mode	0: Two-wire type 1 1: Two-wire type 2 2: Three-wire type 1 3: Three-wire type 2	0	★

F07.12	Terminal UP/DOWN change rate	0.001Hz/s~65.535Hz/s	1.00Hz/s	☆
F07.13	AI curve 1 minimum input	0.00V~F07.15	0.00V	☆
F07.14	AI curve 1 minimum input corresponding setting	-100.0% ~ +100.0%	0.0%	☆
F07.15	AI curve 1 maximum input	F07.13~+10.00V	10.00V	☆
F07.16	AI curve 1 maximum input corresponding setting	-100.0% ~ +1 5 0.0%	100.0%	☆
F07.17	AI1 filter time	0.00s~10.00s	0.10s	☆
F07.18	AI curve 2 minimum input	0.00V~F07.20	0.00V	☆
F07.19	AI curve 2 minimum input corresponding setting	-100.0% ~ +1 0 0.0%	0.0%	☆
F07.20	AI curve 2 maximum input	F07.18~+10.00V	10.00V	☆
F07.21	AI curve 2 maximum input corresponding setting	-100.0% ~ +1 5 0.0%	100.0%	☆
F07.22	AI2 filter time	0.00s~10.00s	0.10s	☆
F07.23	Panel potentiometer minimum input	-10.00V~F07.25	-9.50V	☆
F07.24	Minimum input corresponding setting of panel potentiometer	-100.0% ~ +100.0%	0.0%	☆
F07.25	Panel potentiometer maximum input	F07.23~+10.00V	9.50V	☆

F07.26	Corresponding setting of the maximum input of the panel potentiometer	—100.0% ~ +1 5 0.0%	100.0%	☆
F07.27	Panel potentiometer filter time	0.00s~10.00s	0.10s	☆
F07.28	PULSE minimum input	0.00kHz~F07.30	0.00kHz	☆
F07.29	PULSE minimum input corresponding setting	—100.0%~100.0%	0.0%	☆
F07.30	PULSE maximum input	F07.28~100.00kHz	50.00kHz	☆
F07.31	PULSE maximum input setting	—100.0%~100.0%	100.0%	☆
F07.32	PULSE filter time	0.00s~10.00s	0.10s	☆
F07.33	AI curve selection	Units digit: AI1 curve selection 1: Curve 1 (2 points, see F07.13 ~ F07.16) 2: Curve 2 (2 points, see F07.18 ~ F07.21) 3: Reserved 4: Curve 4 (4 points , see F18.00 ~ F18.07) 5: Curve 5 (4 points, see F18.08 ~ F18.15) Tens digit: AI2 curve selection, the same as above Hundreds digit: reserved	321	☆

F07.34	AI below minimum input setting selection	Units place: AI1 is lower than the minimum input setting selection 0: corresponding to the minimum input setting 1:0.0% Tens' digit: AI2 is lower than the minimum input setting selection, the same as above Hundreds digit : panel potentiometer is lower than the minimum input setting selection, the same as above	000	☆
F07.35	X1 delay time	0.0s~3600.0s	0.0s	★
F07.36	X2 delay time	0.0s~3600.0s	0.0s	★
F07.37	X3 delay time	0.0s~3600.0s	0.0s	★
F07.38	X terminal valid mode selection 1	0: High level is valid 1: Low level is valid Units digit: X1 Tens digit: X2 Hundreds digit: X3 Thousands digit: X4 Ten thousand digit: X5	00000	★

F07.39	X terminal valid mode selection 2	0: Valid at high level 1: Valid at low level Units digit: X6 Tens digit: X7 Hundreds digit: Reserved Thousands digit: Reserved Tens of thousands digit: Reserved	00000	★
F07.40	AI2 input signal selection	0: Voltage signal 1: Current signal	0	★
F08 group output terminal				
function code	name	Predetermined area	Factory default	Change
F08.00	DO/AO2 terminal output mode selection	0: Pulse output (DOP) 1: Switching output (DOR) 2: Analog output (AO2) Note: DOP and DOR are output through the main control board terminal DO, and DO and AO2 can be selected through the main control board jumper socket.	2	☆
F08.01	DOR output function selection	0: No output	0	☆

F08.02	Control board relay R1 function selection	1: The frequency converter is running 2: Fault output (free stop fault) 3: Frequency level detection FDT1 output 4: Frequency arrival signal (FAR) 5: Zero speed running (no output when stopped) 6: Motor overload pre-alarm 7: Frequency converter overload pre-alarm 8: Set count value reached 9: Specified count value reached 10: Length reached 11: PLC cycle completed 12: Accumulated running time reached 13: Frequency limited 14: Torque limited 15: Ready to run 16: AI1>AI2 17: Upper limit frequency reached 18: Lower limit frequency reached (operation related) 19: Undervoltage status output 20: Communication setting 21: Reserved	2	☆
F08.03	Control board relay R2 output function selection	12: Accumulated running time reached 13: Frequency limited 14: Torque limited 15: Ready to run 16: AI1>AI2 17: Upper limit frequency reached 18: Lower limit frequency reached (operation related) 19: Undervoltage status output 20: Communication setting 21: Reserved	0	☆

F08.04	Open collector Y1 output function selection	22: Reserved 23: Zero speed running 2 (stopped) 24 : Accumulated power-on time reaches 25: Frequency level detection FDT2 Output 26: Frequency 1 Arrival output 27: Frequency 2 Arrival output 28: Current 1 Arrival output 29: Current 2 Arrival output 30: Timing arrival output 31: All Input over-limit 32: Load loss	1	☆
F08.05	Open collector Y2 output selection	33: Reverse operation 34: Zero current state 35: Module temperature reached 36: Output current over-limit 37: Lower limit frequency reached (output even when stopped) 38: Alarm output (all faults) 39: Motor over-temperature pre-alarm 40: This running time reaches 41: fault output (it is a free stop fault and no output under voltage) 42: Interlock 1 output 43: Interlock 2 output 44: Interlock 3 output	0	☆

F08.06	DOP output function selection	0: Operating frequency 1: Setting frequency 2: Output current (2 times the rated motor current) 3: Output torque (2 times the rated motor torque) 4: Output power (2 times the rated power) 5: Output voltage (1.2 times Inverter rated voltage) 6: PULSE input (100.0% corresponds to 100.0kHz) 7: AI1 8: AI2 9: Reserved 10: Length 11: Count value 12: Communication setting 13: Motor speed 14: Output current (100.0% corresponds to 1000.0 A) 15: Output voltage (100.0% corresponds to 1000.0V) 16: Output torque (actual torque value)	0	☆
F08.07	AO1 output function selection		0	☆
F08.08	AO2 output function selection		1	☆
F08.09	DOP output maximum frequency	0.01KHz ~ 100.00KHz	50.00Hz	☆
F08.10	AO1 zero bias coefficient	—100.0% ~ +100.0%	0.0%	☆

F08.11	AO1 gain	—10.00~+10.00	1.00	☆
F08.12	AO2 zero bias coefficient	—100.0%~+100.0%	0.0%	☆
F08.13	AO2 gain	—10.00~+10.00	1.00	☆
F08.14 ~F08.1 6	reserve	—	0	☆
F08.17	DOR output delay time	0.0s~3600.0s	0.0s	☆
F08.18	R1 output delay time	0.0s~3600.0s	0.0s	☆
F08.19	R2 output delay time	0.0s~3600.0s	0.0s	☆
F08.20	Y1 output delay time	0.0s~3600.0s	0.0s	☆
F08.21	Y2 output delay time	0.0s~3600.0s	0.0s	☆
F08.22	Switching output terminal valid status selection	0: Positive logic. 1: Negative logic. Units digit: Reserved tens digit: R1 Hundreds digit: R2 Thousands digit: Y1 Thousands digit: Y2	0000	☆

F08.23	AO1 output signal selection	0: Voltage signal 1: Current signal	0	★
F09 group PID function				
function code	name	Predetermined area	Factory default	Change
F09.00	PID given source	0: F09.01 setting 1: AI1 2: AI2 3: Panel potentiometer 4: PULSE pulse setting (X7) 5: Communication given 6: Multi-segment command given 7 : Pressure given (MP a , Kg)	0	☆
F09.01	PID value given	0.0%~100.0%	50.0%	☆
F09.02	PID feedback source	0: AI1 1: AI2 2: Reserved 3: AI1-AI2 4: PULSE pulse setting (X7) 5: Communication reference 6: AI1+AI2 7: MAX(AI1 , AI2) 8: MIN(AI1 , AI2)	0	☆

F09.03	PID action direction	0: Positive effect 1: Reverse effect	0	☆
F09.04	PID given feedback range	0~65535	1000	☆
F09.05	Proportional gain Kp1	0.0~ 999.9	20.0	☆
F09.06	Integration time Ti1	0.01s~10.00s	2.00s	☆
F09.07	Differential time Td1	0.000s~10.000s	0.000s	☆
F09.08	PID inversion cutoff frequency	0.00 ~ maximum frequency	2.00Hz	☆
F09.09	PID deviation limit	0.0%~100.0%	0.0%	☆
F09.10	PID differential limiting	0.00%~100.00%	0.5 0%	☆
F09.11	PID given change time	0.00~650.00s	0.00s	☆
F09.12	PID feedback filter time	0.00~60.00s	0.00s	☆
F09.13	PID output filter time	0.0~ 60 0.0s	10 0.0s	☆
F09.14	reserve	-	-	☆
F09.15	Proportional gain Kp2	0.0~ 999.9	20.0	☆
F09.16	Integration time Ti2	0.01s~10.00s	2.00s	☆
F09.17	Differential time Td2	0.000s~10.000s	0.000s	☆

F09.18	PID parameter switching conditions	0: No switching 1: Switching via X terminal 2: Automatic switching based on deviation 3 ~ 8: Reserved	0	☆
F09.19	PID parameter switching deviation 1	0.0%~F09.20	20.0%	☆
F09.20	PID parameter switching deviation 2	F09.19~100.0%	80.0%	☆
F09.21	PID initial value	0.0%~100.0%	0.0%	☆
F09.22	PID initial value holding time	0.00~650.00s	0.00s	☆
F09.23 ~ F09.24	reserve	—	0	☆
F09.25	PID feedback upper limit loss detection value	0.0%: No judgment, feedback loss 0.1% ~ 100.0%	0.0%	☆
F09.26	PID feedback lower limit loss detection value		0.0%	☆
F09.27	PID feedback loss detection time	0.0s~20.0s	0.0s	☆
F09.28	PID shutdown operation	0: No operation during shutdown 1: Operation during shutdown	0	☆
F10 group multi-segment instructions, simple PLC				
function code	name	Predetermined area	Factory default	Change

F10.00	Multi-segment instruction 0	-100.0%~100.0%	0.0%	☆
F10.01	Multi-segment instruction 1	-100.0%~100.0%	0.0%	☆
F10.02	Multi-segment instruction 2	-100.0%~100.0%	0.0%	☆
F10.03	Multi-segment instruction 3	-100.0%~100.0%	0.0%	☆
F10.04	Multi-segment instructions 4	-100.0%~100.0%	0.0%	☆
F10.05	Multi-segment instructions 5	-100.0%~100.0%	0.0%	☆
F10.06	Multi-segment instructions 6	-100.0%~100.0%	0.0%	☆
F10.07	Multi-segment instruction 7	-100.0%~100.0%	0.0%	☆
F10.08	Multi-segment instructions 8	-100.0%~100.0%	0.0%	☆
F10.09	Multi-segment instructions 9	-100.0%~100.0%	0.0%	☆
F10.10	Multi-segment instructions 10	-100.0%~100.0%	0.0%	☆
F10.11	Multi-segment instructions 11	-100.0%~100.0%	0.0%	☆
F10.12	Multi-segment instructions 12	-100.0%~100.0%	0.0%	☆
F10.13	Multi-segment instructions 13	-100.0%~100.0%	0.0%	☆
F10.14	Multi-segment instructions 14	-100.0%~100.0%	0.0%	☆
F10.15	Multi-segment instructions 15	-100.0%~100.0%	0.0%	☆
F10.16	Simple PLC operation mode	0: Stop at the end of a single run 1: Keep the final value at the end of a single run	0	☆

		2: Keep looping		
F10.17	Simple PLC power-off memory selection	Units digit: Power-off memory selection 0: Power-off no memory 1: Power-off memory Tens digit: Stop memory Select 0: Stop power without memory 1: Stop memory	00	☆
F10.18	Simple PLC segment 0 running time	0.0s(h)~6500.0s(h)	0.0s(h)	☆
F10.19	Simple PLC section 0 acceleration and deceleration time selection	0~3	0	☆
F10.20	Simple PLC first stage running time	0.0s(h)~6500.0s(h)	0.0s(h)	☆
F10.21	Simple PLC first stage acceleration and deceleration time selection	0~3	0	☆
F10.22	Simple PLC second stage running time	0.0s(h)~6500.0s(h)	0.0s(h)	☆
F10.23	Simple PLC second stage acceleration and deceleration time selection	0~3	0	☆

F10.24	Simple PLC 3rd stage running time	0.0s(h)~6500.0s(h)	0.0s(h)	☆
F10.25	Simple PLC 3rd stage acceleration and deceleration time selection	0~3	0	☆
F10.26	Simple PLC 4th segment running time	0.0s(h)~6500.0s(h)	0.0s(h)	☆
F10.27	Simple PLC 4th segment acceleration and deceleration time selection	0~3	0	☆
F10.28	Simple PLC 5th segment running time	0.0s(h)~6500.0s(h)	0.0s(h)	☆
F10.29	Simple PLC 5th segment acceleration and deceleration time selection	0~3	0	☆
F10.30	Simple PLC 6th segment running time	0.0s(h)~6500.0s(h)	0.0s(h)	☆
F10.31	Simple PLC section 6 acceleration and deceleration time selection	0~3	0	☆
F10.32	Simple PLC 7th segment running time	0.0s(h)~6500.0s(h)	0.0s(h)	☆
F10.33	Simple PLC 7th segment acceleration and deceleration time selection	0~3	0	☆

F10.34	Simple PLC 8th segment running time	0.0s(h)~6500.0s(h)	0.0s(h)	☆
F10.35	Simple PLC 8th segment acceleration and deceleration time selection	0~3	0	☆
F10.36	Simple PLC 9th segment running time	0.0s(h)~6500.0s(h)	0.0s(h)	☆
F10.37	Simple PLC 9th segment acceleration and deceleration time selection	0~3	0	☆
F10.38	Simple PLC 10th segment running time	0.0s(h)~6500.0s(h)	0.0s(h)	☆
F10.39	Simple PLC 10th segment acceleration and deceleration time selection	0 ~ 3	0	☆
F10.40	Simple PLC 11th segment running time	0.0s(h)~6500.0s(h)	0.0s(h)	☆
F10.41	Simple PLC 11th segment acceleration and deceleration time selection	0~3	0	☆
F10.42	Simple PLC 12th segment running time	0.0s(h)~6500.0s(h)	0.0s(h)	☆
F10.43	Simple PLC 12th segment acceleration and deceleration time selection	0~3	0	☆
F10.44	Simple PLC 13th segment running time	0.0s(h)~6500.0s(h)	0.0s(h)	☆

F10.45	Simple PLC 13th segment acceleration and deceleration time selection	0~3	0	☆
F10.46	Simple PLC 14th segment running time	0.0s(h)~6500.0s(h)	0.0s(h)	☆
F10.47	Simple PLC 14th segment acceleration and deceleration time selection	0~3	0	☆
F10.48	Simple PLC 15th segment running time	0.0s(h)~6500.0s(h)	0.0s(h)	☆
F10.49	Simple PLC 15th segment acceleration and deceleration time selection	0~3	0	☆
F10.50	Simple PLC running time unit	0: s (seconds) 1: h (hours)	0	☆
F10.51	Multi-segment instruction 0 given mode	0: Function code F10.00 given 1: AI1 2: AI2 3: Panel potentiometer 4: PULSE Pulse 5: PID 6: Preset frequency (F00.08) given, UP/DOWN can be modified	0	☆
Group F11 swing frequency, fixed length and counting				

function code	name	Predetermined area	Factory default	Change
F11.00	Swing frequency setting method	0: Relative to the center frequency 1: Relative to the maximum frequency	0	☆
F11.01	Swing frequency amplitude	0.0%~100.0%	0.0%	☆
F11.02	Kick frequency amplitude	0.0%~50.0%	0.0%	☆
F11.03	Swing frequency period	0.1s~3000.0s	10.0s	☆
F11.04	Triangular wave rise time of swing frequency	0.1%~100.0%	50.0%	☆
F11.05	Set length	0m~65535m	1000m	☆
F11.06	Actual length	0m~65535m	0m	☆
F11.07	pulses per meter	0.1 ~ 6553.5	100.0	☆
F11.08	Set count value	1 ~ 65535	1000	☆
F11.09	Specify count value	1 ~ 65535	1000	☆
F11.10 ~ F11.14	reserve	—	0	☆
Group F12 fault and protection				
function code	name	Predetermined area	Factory default	Change

F12.00	Motor overload protection selection	0: Forbidden 1: Allowed	1	☆
F12.01	Motor overload protection gain	0.20~10.00	1.00	☆
F12.02	Motor overload warning coefficient	50%~100%	80%	☆
F12.03	Overvoltage stall gain	0~100	0	☆
F12.04	Overvoltage stall protection voltage	200.0~ 2000.0	760.0	☆
F12.05	Overcurrent stall gain	0~100	20	☆
F12.06	Overcurrent stall protection current	100%~200%	150%	☆
F12.07	reserve	—	0	☆
F12.08	Braking starting voltage	200.0~2000.0V	690.0V	☆
F12.09	Number of automatic fault resets	0~ 200	0	☆
F12.10	Fault terminal output action selection during automatic fault reset	0: No action 1: Action	1	☆
F12.11	Automatic fault reset interval	0.1s~100.0s	6.0s_	☆
F12.12	Input phase loss protection selection	0: Disabled (inverter power <= 11 kW) 1: Allowed (inverter power >11kW)	Model confirmed	☆

F12.13	Output phase loss protection selection	0: Forbidden 1: Allowed	1	☆
F12.14	First fault type	0: No fault 1: Reserved 2: Acceleration overcurrent 3: Deceleration overcurrent 4: Constant speed overcurrent 5: Acceleration overvoltage 6: Deceleration overvoltage 7: Constant speed overvoltage 8 : Buffer resistor overload 9: Undervoltage 10: Frequency converter overload 11: Motor overload 12: Input phase loss 13: Output phase loss 14: Module overheating 15: External fault 16 : Communication abnormality 17 : Reserved	-	●

F12.15	Second fault type	18: Current detection abnormality 19: Motor tuning abnormality 20: Reserved 21: Parameter reading and writing Abnormality 22: Inverter hardware abnormality 23: Reserved 24: Reserved 25: Reserved	-	•
F12.16	Third (most recent) fault type	26: Running time reached 27: Reserved 28: Reserved 29 : Power-on time reached 30: Load loss 31: PID feedback lost during running 40: Fast current limit timeout 41: Switching the motor during operation 42: Excessive speed deviation 43: Motor overspeed 45: Motor overtemperature 51: Initial position error	-	•
F12.17	Third (most recent) failure frequency	-	-	•
F12.18	Current at the third (most recent) fault	-	-	•

F12.19	Bus voltage at the time of the third (most recent) fault	-	-	●
F12.20	Input terminal status during the third (most recent) fault	-	-	●
F12.21	Output terminal status during the third (most recent) fault	-	-	●
F12.22	The status of the inverter at the time of the third (most recent) fault	-	-	●
F12.23	Power-on time for the third (most recent) failure	-	-	●
F12.24	Run time at third (most recent) failure	-	-	●
F12.27	The frequency of the second failure	-	-	●
F12.28	The current during the second fault	-	-	●
F12.29	Bus voltage during the second fault	-	-	●
F12.30	Input terminal when fault occurs for the second time	-	-	●
F12.31	Output terminal when fault occurs for the second time	-	-	●

F12.32	Inverter status when fault occurs for the second time	-	-	●
F12.33	Power-on time when the second fault occurs	-	-	●
F12.34	Runtime at second failure	-	-	●
F12.37	Frequency at first failure	-	-	●
F12.38	Current at first fault	-	-	●
F12.39	Bus voltage at first fault	-	-	●
F12.40	Input terminal when first fault occurs	-	-	●
F12.41	Output terminal status when the first fault occurs	-	-	●
F12.42	Inverter status at first fault	-	-	●
F12.43	Power-on time at first failure	-	-	●
F12.44	Operating time at first failure	-	-	●
F12.47	Fault protection action selection 1	Units digit: Motor overload (11) 0: Coast to stop 1: Stop according to stop mode 2: Continue running Tens digit: Input phase loss (12) Hundreds digit: Output phase loss (13) Thousands digit: External fault (15) Ten thousand digit : Communication abnormality(16)	OOOOO	☆

F12.48	Fault protection action selection 2	Units digit: Reserved 0: Free stop Tens digit: Function code reading and writing abnormality (21) 0: Free stop 1: Stop according to stop mode Hundreds digit: Reserved Thousands digit: Motor overheating (25) Ten thousand digit: Running time reached (26)	00000	☆
--------	--	---	-------	---

F12.49	Fault protection action selection 3	<p>Units digit: User-defined fault 1 (27) 0: Coast to stop 1: Stop according to the shutdown mode 2: Continue running</p> <p>Tens digit: User-defined fault 2 (28) 0: Coast to stop 1: Stop according to the shutdown mode 2: Continue running</p> <p>Hundreds digit: Power-on time reached (29) 0: Coast to stop 1: Stop according to stop mode 2: Continue running</p> <p>Thousands digit: Load drop (30) 0: Coast to stop 1: Deceleration to stop 2: Jump directly to 7 of the rated frequency of the motor % Continue to run, and automatically return to the set frequency when the load does not drop.</p> <p>Ten thousand digits: PID feedback is lost during operation (31) 0: Coast to stop 1: Stop according to the stop mode 2: Continue to run</p>	OOOOO	☆
--------	--	--	-------	---

F12.50	Fault protection action selection 4	Units digit: Speed deviation is too large (42) 0: Coast to stop 1: Stop according to stop mode 2: Continue running Tens, hundreds, thousands, ten thousand digits: reserved	00000	☆
F12.54	Continue running frequency selection in case of failure	0: Run at the current operating frequency 1: Run at the set frequency 2: Run at the upper limit frequency 3: Run at the lower limit frequency 4: Run at the abnormal backup frequency	0	☆
F12.55	Abnormal backup frequency	0.0% ~ 100.0% (100.0% corresponds to the maximum frequency F00.10)	100.0%	☆
F12.56	Motor temperature sensor type	0: No temperature sensor 1: PT100 2: PT1000	0	☆
F12.57	Motor overheat protection threshold	0°C ~ 200°C	110°C	☆
F12.58	Motor overheating pre-alarm threshold	0°C ~ 200°C	90°C	☆
F12.59	Instantaneous power outage action selection	0: Invalid 1: Deceleration 2: Deceleration to stop	0	☆

F12.60	Momentary stop action pauses to judge voltage	80.0%~100.0%	85.0 %	☆
F12.61	Instantaneous power outage voltage recovery judgment time	0.00s~100.00s	0.50s	☆
F12.62	Instantaneous power outage action judgment voltage	60.0% ~ 100.0% (standard bus voltage)	80.0%	☆
F12.63	Load loss protection options	0: invalid 1: valid	0	☆
F12.64	Load shedding detection level	0.0~100.0%	10.0%	☆
F12.65	Load drop detection time	0.0~60.0s	1.0s	☆
F12.66	reserve	—	0	☆
F12.67	reserve	—	0	☆
F12.68	SVC speed deviation excessive detection value	0.0%~50.0% (maximum frequency)	20.0%	☆
F12.69	SVC speed deviation excessive detection time	0.0s: No detection 0.1 ~ 60.0s	0.0s _	☆
F12.70	Instant stop and non-stop gain K _p	0~100	40	☆
F12.71	Instantaneous stop integral coefficient K _i	0~100	30	☆
F12.72	Instant stop and non-stop action deceleration time	0.0~300.0s	20.0s	☆

F13 group communication parameters

function code	name	Predetermined area	Factory default	Change
F13.00	MODBUS communication baud rate	0~1: Reserved 2: 1200BPS 3: 2400BPS 4: 4800BPS 5: 9600BPS 6: 19200BPS 7: 38400BPS 8: 57600BPS 9: 115200BPS	5	☆
F13.01	MODBUS data format	0: No parity (8-N-2) 1: Even parity (8-E-1) 2: Odd parity (8-O-1) 3: No parity (8-N-1)	0	☆
F13.02	Local address	0: Broadcast address 1 ~ 247	1	☆
F13.03	MODBUS response delay	0~20ms	2	☆
F13.04	RS485 communication timeout time	0.0: Invalid 0.1 ~ 60.0s	0.0s	☆
F13.05	MODBU protocol selection	0: Non-standard MODBUS protocol 1: Standard MODBUS protocol	0	☆
F13.06	RS485 communication reading current resolution	0:0.01A 1:0.1A	0	☆

F13.0 7	reserve	reserve	0	☆
F14 group keyboard and display				
function code	name	Predetermined area	Factory default	Change
F14.00	FUNC key function selection	<p>0: FUNC key is invalid 1: Switch between operation panel command channel and remote command channel (terminal command channel or communication command channel) 2: Forward and reverse rotation switching 3: Forward rotation jog 4: Reverse rotation jog Note: F14.00=1 When, switch to the terminal running command, the auxiliary display of the units digital tube will flash slowly at intervals of 1s; switch to the communication operation command channel, the auxiliary display of the units digital tube will flash at intervals of 200ms.</p>	3	★
F14.01	STOP/RESET key function	<p>0: Only in keyboard operation mode, the STOP/RES key stop function is valid 1: In any operation mode, the STOP/RES key stop function is valid</p>	1	☆

F14.02	LED running main display parameter 1	0000 ~ FFFF Bit00: Operating frequency 1 (Hz) Bit01: Set frequency (Hz) Bit02: Bus voltage (V) Bit03: Output voltage (V) Bit04: Output current (A) Bit05: Output power (kW) Bit06: Output Torque (%) Bit07: Terminal input status Bit08: Terminal output status Bit09: AI1 voltage (V) Bit10: AI2 voltage (V) Bit11: Pressure feedback (MPa, Kg) Bit12: Count value Bit13: Length value Bit14: Load speed Display Bit15: PID setting	1F	☆
--------	--------------------------------------	--	----	---

F14.03	LED running main display parameter 2	0000 ~ FFFF Bit00: PID feedback Bit01: PLC stage Bit02: PULSE input pulse frequency (kHz) Bit03: Running frequency 2 (Hz) Bit04: Remaining running time Bit05: AI1 voltage before correction (V) Bit06: AI2 voltage before correction (V) Bit07: Pressure setting (MPa, Kg) Bit08: Line speed Bit09: Current power-on time (Hour) Bit10: Current running time (Min) Bit11: PULSE input pulse frequency (Hz) Bit12: Communication setting value Bit13: Reserved Bit14: Display of main frequency A (Hz) Bit15: Display of auxiliary frequency B (Hz)	0	☆
--------	--------------------------------------	---	---	---

F14.04	LED shutdown main display parameters	0000 ~ FFFF Bit00: Set frequency (Hz) Bit01: Bus voltage (V) Bit02: Terminal input status Bit03: Terminal output status Bit04 : AI1 voltage (V) Bit05 : AI2 voltage (V) Bit06: Panel potentiometer voltage (V) Bit07: Count value Bit08: Length value Bit09: PLC stage Bit10: Load speed Bit11: PID setting Bit12: PULSE input pulse frequency (kHz) Bit1 3 : Pressure feedback (MPa, Kg) Bit1 4 : Input voltage (V) Bit1 5 : Reserved	33	☆
F14.05	LED operating auxiliary display parameters	0 ~ 80	4	☆
F14.06	LED shutdown auxiliary display parameters	0 ~ 80	38	☆
F14.07	Load speed display coefficient	0.0001 ~ 6.5000	1.0000	☆
F14.08	Inverter module heat sink temperature	0.0°C ~ 100.0°C	-	●
F14.09	Cumulative running time	0h ~ 65535h	-	●

F14.10	Number of decimal points for speed display	LED units digit: load speed (d00.14) display coefficient 0: 0 decimal place 1: 1 decimal place 2: 2 decimal places 3: 3 decimal places LED tens digit: feedback speed (d00.19) display coefficient 1: 1 decimal place 2: 2 decimal places	21	☆
F14.11	Accumulated power-on time	0 ~ 65535 hours	-	●
F14.12	Cumulative power consumption	0 ~ 65535 degrees	-	●
F14.13	Hardware version number	-	-	●
F14.14	Software version number	-	-	●
F14.15	Software batch number	-	3.0 410	●
F15 group function code management				
function code	name	Predetermined area	Factory default	Change
F15.00	user password	0~65535	0	☆

F15.01	Parameter initialization	0: No operation 1: All user parameters except motor parameters are restored to factory settings 2: All user parameters are restored to factory settings 3: Clear record information	0	★
F15.02	Function code modification attribute	0: Modifiable 1: Unmodifiable	0	☆
F15.03	reserve	—	0	●
F15.04	reserve	—	0	●
F16 group water supply parameter group				
function code	name	Predetermined area	Factory default	Change
F16.00	Terminal access and disconnection delay	0.0~6000.0s	0.1	☆
F16.01	Polling time	0.0~6000.0h	48.0	☆
F16.02	Reduce pump lower limit frequency	0.0~ upper limit frequency	35.00	☆
F16.03	Pump delay time	0.0~3600.0s	5.0	☆
F16.04	Decrease pump delay time	0.0~3600.0s	5.0	☆

F16.05	Water pump sleep wait time	0.0~3600.0s	2.0	☆
F16.06	Water pump wake-up waiting time	0.0~3600.0s	1.0	☆
F16.07	Water pump wakes up pressure points	(0.0~100.0%)* (F16.08)	80.0%	☆
F16.08	Preset pressure	0.00~F16.09 (MPa, Kg)	5.00	☆
F16.09	Sensor range	0.00~100.00 (MPa, Kg)	10.00	☆
F16.10	Maximum power node of the battery panel	0.0%~100.0%	81.0	☆
F16.11	VF speed adjustment coefficient	0.000~2.000	1.000	☆
F16.12	MPPT high point working voltage	(F16.13)~200.0%	100.0%	☆
F16.13	MPPT low point working voltage	0.0%~(F16.12)	75.0%	☆
F16.14	MPPT high point voltage frequency point	0.00Hz~maximum frequency (F00.10)	50.00	☆
F16.15	MPPT low point voltage frequency point	0.00Hz~maximum frequency (F00.10)	0.00	☆
F16.16	MPPT low voltage protection point	40.0%~100.0%	45.0%	☆
F16.17	Water shortage detection starting frequency	0.00Hz~maximum frequency (F00.10)	10.00	☆
F16.18	Photovoltaic water pump water shortage detection current	0.0%~300.0%* no-load current (F03.10)	0.0	☆

	corresponding to no-load current ratio			
F16.19	Photovoltaic water pump water shortage detection time	0~6000.0s	0.0	☆
F16.20	Photovoltaic undervoltage self-start delay	0.1~6000.0s (0.0 value turns off auto-start)	2.0	☆
F16.21	Photovoltaic water shortage self-start delay	0.1~6000.0s (0.0 value turns off auto-start)	15.0	☆
F16.22	Power search time	0.050~60.000	0.500	☆
F16.23	power search gain	10~500	125	☆
F16.24	Power search speed gain	1~1000	100	☆
F16.25	Pre-search upscaling time	0.01~600.00s	15.00	☆
F16.26	Pre-search downclocking time	0.01~600.00s	15.00	☆
F17 group control optimization parameters				
function code	name	Predetermined area	Factory default	Change
F17.00	DPWM switching upper limit frequency	0.00Hz ~ maximum frequency (F00.10)	8.00Hz	☆
F17.01	PWM modulation method	0: Asynchronous modulation 1: Synchronous modulation	0	☆

F17.02	Dead zone compensation mode selection	0: No compensation 1: Compensation mode	1	☆
F17.03	Random PWM depth	0: Random PWM is invalid 1 ~ 10: PWM carrier frequency random depth	0	☆
F17.04	Wave-by-wave current limit enable	0: Disabled 1: Enabled	1	☆
F17.05	Voltage overmodulation coefficient	100~110	105	☆
F17.06	Undervoltage point setting	200.0V ~ 2000.0V	350.0V	☆
F17.07	reserve	—	0	☆
F17.08	Overvoltage point setting	200.0V ~ 2200.0V	Model confirmed	★
F18 group AI curve setting				
function code	name	Predetermined area	Factory default	Change
F18.00	AI curve 4 minimum input	—10.00V~F18.02	0.00V	☆
F18.01	AI setting curve 4 minimum input corresponding setting	—100.0% ~ +100.0%	0.0%	☆
F18.02	AI curve 4 inflection point 1 input	F18.00~F18.04	3.00V	☆
F18.03	AI curve 4 inflection point 1 input corresponding setting	—100.0% ~ +100.0%	30.0%	☆

F18.04	AI curve 4 inflection point 2 input	F18.02 ~ F18.06	6.00V	☆
F18.05	AI curve 4 inflection point 2 input corresponding setting	-100.0% ~ +100.0%	60.0%	☆
F18.06	AI curve 4 maximum input	F18.06 ~ +10.00V	10.00V	☆
F18.07	AI curve 4 maximum input corresponding setting	-100.0% ~ +100.0%	100.0%	☆
F18.08	AI curve 5 minimum input	-10.00V ~ F18.10	-10.00V	☆
F18.09	AI curve 5 minimum input corresponding setting	-100.0% ~ +100.0%	-100.0%	☆
F18.10	AI curve 5 inflection point 1 input	F18.08 ~ F18.12	-3.00V	☆
F18.11	AI curve 5 inflection point 1 input corresponding setting	-100.0% ~ +100.0%	-30.0%	☆
F18.12	AI curve 5 inflection point 2 input	F18.10 ~ F18.14	3.00V	☆
F18.13	AI curve 5 inflection point 2 input corresponding setting	-100.0% ~ +100.0%	30.0%	☆
F18.14	AI curve 5 maximum input	F18.12 ~ +10.00V	10.00V	☆
F18.15	AI curve 5 maximum input corresponding setting	-100.0% ~ +100.0%	100.0%	☆
F18.16	All sets jump point	-100.0% ~ 100.0%	0.0%	☆
F18.17	All sets jump amplitude	0.0% ~ 100.0%	0.1 %	☆

F18.18	AI2 sets jump point	—100.0%~100.0%	0.0%	☆
F18.19	AI2 sets jump amplitude	0.0%~100.0%	0.1 %	☆
F18.2 0	Panel potentiometer sets jump point	—100.0%~100.0%	0.0%	☆
F18.2 1	Panel potentiometer sets jump amplitude	0.0%~100.0%	0.1 %	☆
FFF group manufacturer parameters				
function code	name	Predetermined area	Factory default	Change
FFF.00	Manufacturer password	0~65535	0	★
d00 group basic monitoring parameters				
function code	name		Factory default	Change
d00.00	Operating frequency (Hz)		0.01Hz	7000H
d00.01	Set frequency (Hz)		0.01Hz	7001H
d00.02	Bus voltage (V)		0.1V	7002H
d00.03	Output voltage(V)		1V	7003H
d00.04	Output current(A)		0.01A	7004H
d00.05	Output power(kW)		0.1kW	7005H
d00.06	Output torque(%)		0.10%	7006H

d00.07	Terminal input status	1	7007H
d00.08	Terminal output status	1	7008H
d00.09	AI1 voltage (V)/current (mA)	0.01V/0.01mA	7009H
d00.10	AI2 voltage (V)	0.01V	700AH
d00.11	Pressure feedback (MPa, Kg)	0.00	700BH
d00.12	count value	1	700CH
d00.13	length value	1	700CH
d00.14	Load speed display	1	700EH
d00.15	PID setting	1	700FH
d00.16	PID feedback	1	7010H
d00.17	PLC stage	1	7011H
d00.18	PULSE input pulse frequency (Hz)	0.01kHz	7012H
d00.19	Feedback speed(Hz)	0.01Hz	7013H
d00.20	remaining run time	0.1Min	7014H
d00.21	AI1 voltage before correction (V)/current (mA)	0.001V/0.01mA	7015H
d00.22	AI2 voltage before correction (V)	0.001V	7016H

d00.23	Pressure setting (MPa, Kg)	0.00	7017H
d00.24	Line speed	1m/Min	7018H
d00.25	Current power-on time	1Min	7019H
d00.26	Current running time	0.1Min	701AH
d00.27	PULSE input pulse frequency	1Hz	701BH
d00.28	Communication settings	0.01%	701CH
d00.29	reserve	0	701CH
d00.30	Main frequency A display	0.01Hz	701FH
d00.31	Auxiliary frequency B display	0.01Hz	701FH
d00.32	reserve	0	7020H
d00.33	reserve	0	7021H
d00.34	Motor temperature value	1℃	7022H
d00.35	Target torque(%)	0.1%	7023H
d00.36	reserve	0	7024H
d00.37	power factor angle	0.1°	7025H
d00.38	Input voltage (V)	0.0 V _	7026H

d00.39	VF separation target voltage	1V	7027H
d00.40	VF split output voltage	1V	7028H
d00.41	Input terminal status intuitive display	1	7029H
d00.42	Intuitive display of output terminal status	1	702AH
d00.43	Input terminal function status visual display 1 (function 01-function 40)	1	702BH
d00.44	Input terminal function status visual display 2 (function 41-function 80)	1	702CH
d00.45	accident details	1	702DH
d00.58	reserve	0	703AH
d00.59	Set frequency (%)	0.01%	703BH
d00.60	Operating frequency (%)	0.01%	703CH
d00.61	Inverter status	1	703DH
d00.62	Current fault code	1	703EH
d00.63	reserve	0.00%	703FH
d00.64	reserve	0.01%	7040H
d00.65	Torque upper limit	0.10%	7041H

Chapter Seven EM C (Electromagnetic Compatibility)

7.1 Definition

Electromagnetic compatibility means that electrical equipment operates in an environment with electromagnetic interference, does not interfere with the electromagnetic environment, and can achieve its goals stably. Functional capabilities.

7.2 Introduction to EMC standards

According to the requirements of the national standard GB/T12668.3 , the inverter needs to meet the requirements of electromagnetic interference and anti-electromagnetic interference.

Our company's existing products comply with the latest international standards: IEC/EN 61800-3 : 2004 (Adjustable speed electrical power drive systems part 3: EMC requirements and specific test methods), which is equivalent to the national standard GB/T12668. 3 .

IEC/EN61800-3 mainly examines frequency converters from two aspects: electromagnetic interference and anti-electromagnetic interference. Electromagnetic interference mainly Test the radiated interference, conducted interference and harmonic interference of the frequency converter (this requirement is required for frequency converters used in civil applications). anti- Electromagnetic interference mainly affects the conduction immunity, radiation immunity, surge immunity, rapid mutation pulse group immunity, ESD immunity and power supply low-frequency end immunity of the frequency converter (specific test items are:

1. Immunity test for input voltage sag, interruption and change;
2. Commutation notch immunity test;
3. Harmonic input immunity test;
4. Input frequency change test;

-
5. Input voltage imbalance test;
 6. Input voltage fluctuation test) for testing. Tested in accordance with the above-mentioned strict requirements of IEC/EN61800-3 , our products are installed and used according to the guidance shown in 7.3 , and will have good electromagnetic compatibility in general industrial environments.

7.3 EMC guidance

7.3.1 Influence of harmonics :

High-order harmonics in the power supply will cause damage to the inverter. Therefore, in some places where the power grid quality is relatively poor, it is recommended to install an AC input reactor.

7.3.2 Electromagnetic interference and installation precautions :

There are two types of electromagnetic interference, one is the interference of the electromagnetic noise of the surrounding environment to the inverter, and the other is the interference caused by the inverter to the surrounding equipment.

Installation Precautions:

- 1) The grounding wires of frequency converters and other electrical products should be well grounded;
- 2) The power input and output lines of the frequency converter and weak current signal lines (such as control lines) should not be arranged in parallel. The pieces are arranged vertically;
- 3) It is recommended to use shielded cables for the output power lines of the frequency converter, or use steel pipes to shield the power lines, and the shielding layer must be reliably connected. It is recommended to use twisted-pair shielded control lines for the leads of the interfered equipment, and the shielding layer should be reliably grounded;
- 4) For motor cables longer than 100m , an output filter or reactor is required.

7.3.3 Methods to deal with interference caused by surrounding electromagnetic equipment to the inverter:

Generally, the reason for the electromagnetic influence on the frequency converter is that a large number of relays, contactors or electromagnetic brakes are installed near the frequency converter. When the inverter malfunctions due to interference, it is recommended to adopt the following solutions:

- 1) Install surge suppressors on devices that cause interference;
- 2) Install a filter at the input end of the frequency converter, refer to 7.3.6 for details ;
- 3) The leads of the inverter control signal line and detection line should be shielded cables, and the shielding layer should be grounded reliably.

7.3.4 How to deal with the interference caused by the frequency converter to peripheral equipment:

This part of the noise is divided into two types: one is the radiation interference of the frequency converter, and the other is the conduction interference of the frequency converter. These two types of interference cause surrounding electrical equipment to be subject to electromagnetic or electrostatic induction. This causes the equipment to malfunction. for several different interferences In this case, please refer to the following methods to solve the problem:

- 1) The signals of instruments, receivers and sensors used for measurement are generally relatively weak. If they are close to the inverter or in In the same control cabinet, it is easy to be interfered and cause malfunction. It is recommended to adopt the following methods to solve the problem: try to stay away from interference source; do not arrange signal lines and power lines in parallel, especially do not bundle them together in parallel; use screens for signal lines and power lines Shielded wire and good grounding; add a ferrite magnetic ring on the output side of the inverter (select the suppression frequency within the range of 30 to 1000MHz), and wind 2 to 3 turns in the same direction. For severe conditions, you can choose to install it EMC output filter;

- 2) When the interfered equipment and the inverter use the same power supply, conduction interference will occur. If the above methods cannot eliminate it, If interference occurs, an EMC filter should be installed between the inverter and the power supply (refer to 7.3.6 for specific selection operations);

3) Peripheral equipment is grounded separately to eliminate interference caused by leakage current in the ground wire of the frequency converter when the ground is shared.

7.3.5 Leakage current and treatment:

There are two forms of leakage current when using a frequency converter: one is the leakage current to the ground; the other is the leakage current between lines.

1) Factors affecting ground leakage current and solutions:

There is distributed capacitance between the wire and the ground. The greater the distributed capacitance, the greater the leakage current; effectively reducing the distance between the inverter and the motor. Reduce distributed capacitance. The greater the carrier frequency, the greater the leakage current. The carrier frequency can be reduced to reduce leakage current. But lowering the carrier frequency will As a result, the motor noise increases. Please note that installing a reactor is also an effective way to solve the leakage current.

The leakage current will increase as the loop current increases, so when the motor power is large, the corresponding leakage current will be large.

2) Factors causing leakage current between lines and their solutions:

There is distributed capacitance between the inverter output wiring. If the current passing through the line contains high-order harmonics, it may cause resonance and cause leakage current. If a thermal relay is used at this time, it may malfunction.

The solution is to reduce the carrier frequency or install an output reactor. When using a frequency converter, it is recommended that there be no Install a thermal relay and use the electronic overcurrent protection function of the frequency converter.

7.3.6 Precautions when installing an EMC input filter at the power input end :

1)  Note : When using the filter, please use it strictly in accordance with the rated value; since the filter belongs to Class I electrical appliances, the metal outer shell of the filter The shell ground should be in good contact with the metal ground of the installation cabinet over a large area, and it is required to have good conductive continuity, otherwise there will be contact. Electrical hazards and serious impact on EMC effects;

-
- 2) Through EMC testing, it was found that the filter ground must be connected to the same public ground as the PE terminal ground of the frequency converter, otherwise it will seriously affect the EMC effect .
 - 3) The filter should be installed as close as possible to the power input end of the inverter.

Chapter Eight Fault diagnosis and countermeasures

8.1 Fault alarm and countermeasures

During operation, if an abnormality occurs, the inverter immediately blocks the PWM output and enters the fault protection state. At the same time, the current fault information is indicated by a flashing fault code displayed on the keyboard. At the same time, the fault indicator light ALM lights up. At this time, you need to check the cause of the fault and the corresponding processing method according to the instructions in this section. If the problem still cannot be solved, please contact our company directly. For corresponding solutions, please refer to Table 9-1 for troubleshooting and troubleshooting.

Fault name	Operation panel display	Troubleshooting	Troubleshooting Countermeasures
Inverter unit protection	E-01	<ol style="list-style-type: none">1. The output circuit of the inverter is short-circuited2. The wiring between the motor and the inverter is too long3. The module is overheated4. The internal wiring of the inverter is loose5. The main control board is abnormal6. The drive board is abnormal7. The inverter module is abnormal	<ol style="list-style-type: none">1. Troubleshoot peripheral faults2. Install a reactor or output filter3. Check whether the air duct is blocked, whether the fan is working properly and eliminate existing problems4. Plug in all connecting wires5. Seek technical support6. Seek technical support7. seek technical support

acceleration overcurrent	E-02	<ol style="list-style-type: none"> 1. There is grounding or short circuit in the output circuit of the frequency converter. 2. The control mode is vector and no parameter identification is performed. 3. The acceleration time is too short. 4. The manual torque boost or the V/F curve is inappropriate . 5. The voltage is low 6. The machine is rotating. The motor is started 7. The load is suddenly added during acceleration 8. The inverter selection is too small 	<ol style="list-style-type: none"> 1. Troubleshoot peripheral faults 2. Identify motor parameters 3. Increase acceleration time 4. Adjust manual torque boost or V/F curve 5. Adjust voltage to normal range 6. Select speed tracking start or wait for the motor to stop before starting 7. Cancel sudden load 8. Choose an inverter with a higher power level
Deceleration overcurrent	E-03	<ol style="list-style-type: none"> 1. There is grounding or short circuit in the output circuit of the frequency converter 2. The control mode is vector and no parameter identification is carried out. 3. The deceleration time is too short. 4. The voltage is low 5. The load is suddenly added during the deceleration process. 6. No braking unit and brake are installed. dynamic resistance 	<ol style="list-style-type: none"> 1. Troubleshoot peripheral faults 2. Identify motor parameters 3. Increase deceleration time 4. Adjust voltage to normal range 5. Cancel sudden load 6. Install braking unit and resistor

Constant speed overcurrent	E-04	<ol style="list-style-type: none"> 1. There is grounding or short circuit in the output circuit of the frequency converter . 2. The control mode is vector and no parameter identification is performed. 3. The voltage is low . 4. Is there a sudden load during operation? 5. The frequency converter selection is too small. 	<ol style="list-style-type: none"> 1. Troubleshoot peripheral faults 2. Identify motor parameters 3. Adjust the voltage to the normal range 4. Cancel the sudden load 5. Select an inverter with a larger power level
acceleration overvoltage	E-05	<ol style="list-style-type: none"> 1. The input voltage is too high . 2. There is external force to drive the motor during acceleration . 3. The acceleration time is too short . 4. No braking unit and braking resistor are installed. 	<ol style="list-style-type: none"> 1. Adjust the voltage to the normal range 2. Cancel the external power or install a braking resistor 3. Increase the acceleration time 4. Install a braking unit and resistor
Deceleration overvoltage	E-06	<ol style="list-style-type: none"> 1. The input voltage is too high . 2. There is an external force to drive the motor during the deceleration process. 3. The deceleration time is too short . 4. No braking unit and braking resistor are installed. 	<ol style="list-style-type: none"> 1. Adjust the voltage to the normal range 2. Cancel the external power or install a braking resistor 3. Increase the deceleration time 4. Install a braking unit and resistor
Constant speed overvoltage	E-07	<ol style="list-style-type: none"> 1. The input voltage is too high. 2. There is an external force driving the motor during operation. 	<ol style="list-style-type: none"> 1. Adjust the voltage to the normal range 2. Cancel the external power or install

			a braking resistor
Control power failure	E-08	1. The input voltage is not within the range specified by the specification.	1. The input voltage is not within the range specified by the specification.
Undervoltage fault	E-09	1. Instantaneous power outage 2. The input voltage of the inverter is not within the range required by the specification 3. The bus voltage is abnormal 4. The rectifier bridge and buffer resistor are abnormal 5. The drive board is abnormal 6. The control board is abnormal	1. Reset the fault 2. Adjust the voltage to the normal range 3. Seek technical support 4. Seek technical support 5. Seek technical support 6. Seek technical support
Frequency converter overload	E-10	1. Whether the load is too large or the motor is blocked. 2. The inverter selection is too small.	1. Reduce the load and check the condition of the motor and machinery 2. Choose an inverter with a larger power level
Motor overload	E-11	1. The three-phase input power supply is abnormal. 2. The drive board is abnormal 3. The lightning protection board is abnormal 4. The main control board is abnormal.	1. Check and eliminate problems in peripheral lines 2. Seek technical support 3. Seek technical support 4. Seek technical support

Input phase loss	E-12	<ol style="list-style-type: none"> 1. The three-phase input power supply is abnormal. 2. The drive board is abnormal 3. The lightning protection board is abnormal 4. The main control board is abnormal. 	<ol style="list-style-type: none"> 1. Check and eliminate problems in peripheral lines 2. Seek technical support 3. Seek technical support 4. Seek technical support
Output phase loss	E-13	<ol style="list-style-type: none"> 1. The lead wire from the inverter to the motor is abnormal 2. The three-phase output of the inverter is unbalanced when the motor is running 3. The drive board is abnormal 4. The module is abnormal 	<ol style="list-style-type: none"> 1. Troubleshoot peripheral faults 2. Check whether the three-phase windings of the motor are normal and troubleshoot 3. Seek technical support 4. Seek technical support
Module overheated	E-14	<ol style="list-style-type: none"> 1. The ambient temperature is too high 2. The air duct is blocked 3. The fan is damaged 4. The module thermistor is damaged 5. The inverter module is damaged 	<ol style="list-style-type: none"> 1. Reduce the ambient temperature 2. Clean the air duct 3. Replace the fan 4. Replace the thermistor 5. Replace the inverter module
External device failure	E-15	<ol style="list-style-type: none"> 1. Input external fault signal through multi-function terminal X 	<ol style="list-style-type: none"> 1. Reset operation
communication fail	E-16	<ol style="list-style-type: none"> 1. The host computer is not working properly 2. The communication line is not normal 3. The communication expansion card 	<ol style="list-style-type: none"> 1. Check the host computer wiring 2. Check the communication connection cable 3. Correctly set the communication expansion card type

		F00.28 is set incorrectly 3. The communication parameter F13 group is set incorrectly	4. Correctly set the communication parameters
Current detection failure	E-18	1. Check if the Hall device is abnormal. 2. The driver board is abnormal.	1. Replace the Hall device 2. Replace the driver board
Motor tuning failure	E-19	1. The motor parameters are not set according to the nameplate. 2. The parameter identification process times out.	1. Set the motor parameters correctly according to the nameplate. 2. Check the leads from the inverter to the motor.
EEPROM read and write failure	E-21	1. EEPROM chip is damaged	1. Replace the main control board
Inverter hardware failure	E-22	1. There is overvoltage. 2. There is overcurrent.	1. Handle according to over-voltage fault 2. Handle according to over-current fault
Cumulative running time reached fault	E-26	1. The cumulative running time reaches the set value	1. Use parameter initialization function to clear record information
User defined fault 1	E-27	1. Input the signal of user-defined fault 1 through multi-function terminal X	1. Reset operation
User defined fault 2	E-28	1. Input the signal of user-defined fault 2 through multi-function terminal	1. Reset operation

		X	
Accumulated power-on time reached fault	E-29	1. The cumulative power-on time reaches the set value	1. Use parameter initialization function to clear record information
load loss fault	E-30	1. The operating current of the frequency converter is less than F12-64	1. Confirm whether the load is detached or whether the parameter settings of F12-64 and F12-65 comply with the actual operating conditions.
feedback loss failure during runtime	E-31	1. PID feedback is less than F09.26 setting value	1. Check the PID feedback signal or set F09.26 to an appropriate value
Wave-by-wave current limiting fault	E-40	1. Whether the load is too large or the motor is blocked. 2. The inverter selection is too small.	1. Reduce the load and check the condition of the motor and machinery 2. Choose an inverter with a larger power level
Excessive speed deviation fault	E-42	1. No parameter identification was performed. 2. The speed deviation is too large and the detection parameters F12 . 68~F12 . 69 are set unreasonably.	1. Identify the motor parameters 2. Set the detection parameters reasonably according to the actual situation
Initial position error	E-51	1. The motor parameters deviate too much from the actual ones.	1. Reconfirm whether the motor parameters are correct, focusing on whether the rated current is set too small.

Master-slave control slave failure	E-55	The slave machine fails, check the slave machine	Start troubleshooting according to the slave machine fault code
Brake pipe protection failure	E-60	The braking resistor is short-circuited or the braking module is abnormal.	Check the braking resistor or seek technical support
Photovoltaic water shortage detection failure	E-65	Photovoltaic water pump water shortage detection failure	For details, please refer to the instructions of F16.10~F16.26

Common faults and their solutions

serial number	Fault phenomenon	Possible Causes	Solution
1	No display after power on	The grid voltage is not present or too low; the switching power supply on the drive board of the inverter is faulty; the rectifier bridge is damaged; the buffer resistor of the inverter is damaged; the control board and keyboard are faulty; the connection between the control board and the drive board and keyboard is broken.	Check the input power supply; check the bus voltage; seek service from the manufacturer;

2	"P.OFF" is displayed when powering on	The connection between the drive board and the control board is in poor contact; the relevant components on the control board are damaged; the motor or motor wires are short-circuited to ground; Hall failure; the grid voltage is too low	Seek manufacturer services;
3	The inverter displays normally after powering on. After running, it displays "P.OFF" and shuts down immediately.	The fan is damaged or blocked; there is a short circuit in the peripheral control terminal wiring;	Replace the fan; eliminate external short circuit fault;
4	Frequently reports E-14 (module overheating) fault	The carrier frequency setting is too high. The fan is damaged or the air duct is blocked. The internal components of the inverter are damaged (thermocouple or other)	Reduce the carrier frequency (F00.15); replace the fan and clean the air duct; seek service from the manufacturer;
5	The motor does not rotate after the inverter is running.	Motor and motor wire; wrong inverter parameter settings (motor parameters); poor connection between the drive board and the control board; drive board failure;	Reconfirm the connection between the inverter and the motor; replace the motor or clear the mechanical fault; check and reset the motor parameters;

6	X terminal fails.	Parameter setting error; external signal error; control board failure;	Check and reset the relevant parameters of group F07; reconnect the external signal line; seek manufacturer service;
7	The frequency converter frequently reports overcurrent and overvoltage faults.	The motor parameter settings are incorrect; the acceleration and deceleration time is inappropriate; the load fluctuates;	Reset motor parameters or perform motor tuning; set appropriate acceleration and deceleration times; seek manufacturer service;
8	All digital tubes light up after power-on	The relevant components on the control board are damaged;	Replace control board;

Appendix 1: Modbus communication protocol

H901 series inverters provide RS485 communication interface and support Modbus-RTU slave communication protocol. Users can calculate

Computer or PLC realizes centralized control. Through this communication protocol, the inverter operating commands are set, function code parameters are modified or read, and

Get the working status and fault information of the frequency converter.

1. Agreement content

This serial communication protocol defines the information content and usage format transmitted in serial communication. These include: Host polling (or broadcast)

Format; the encoding method of the host, including: function codes requiring actions, transmission data and error checking, etc. Response from slave

It also uses the same structure, including: action confirmation, return data and error checking, etc. If the slave is receiving information

If an error occurs, or the action required by the host cannot be completed, it will organize a fault message and feed it back to the host as a response.

2. Application method

The frequency converter is connected to the "single master multiple slaves" PC/PLC control network with RS485 bus and serves as a communication slave.

3. Bus structure

(1) Hardware interface

Inverter terminals 485+ and 485- are Modbus communication interfaces.

(2) Topological structure

Single master multi-slave system. Each communication device in the network has a unique slave address. One of the devices serves as the communication host (usually a flat PC host computer, PLC, HMI, etc.), actively initiates communication, and performs parameter reading or writing operations on the slave. Other devices are communication slaves, responding to the host's inquiries or communication operations on this machine. Only one device can send data at the same time while other devices are receiving. The setting range of the slave address is 1 ~ 247, 0 is the broadcast communication address. Slave addresses in the network must be unique.

(3) Communication transmission method

Asynchronous serial, half-duplex transmission mode. During the serial asynchronous communication process, data is sent one frame at a time in the form of messages. The MODBUS-RTU protocol stipulates that when the idle time without data on the communication data line is greater than the transmission time of 3.5Byte, it indicates a new The beginning of the communication frame.

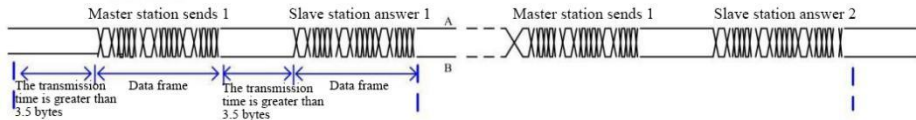

The built-in communication protocol of H901 series inverter is Modbus-RTU slave communication protocol, which can respond to the host's "query/command", or take corresponding actions according to the host's "query/command", and communicate data responses.

The host can refer to a personal computer (PC), industrial control equipment or programmable logic controller (PLC), etc. The host can communicate with a slave machine alone, and can also publish broadcast information to all subordinate slave machines. For the host's separate access "query/command", the accessed slave must return a response frame; for the broadcast information sent by the host, the slave does not need to feedback a response to the host.

4. Communication data structure

The Modbus protocol communication data format of the H901 series inverter is as follows. The inverter only supports reading or writing of Word-type parameters, and the corresponding communication read operation command is 0x03; the write operation command is 0x06, and does not support the reading and writing of bytes or bits :

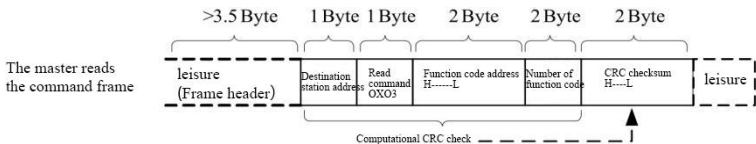

Theoretically, the host computer can read several consecutive function codes at one time (that is, n can be up to 12), but be careful not to cross the last function code of this function code group, otherwise an error will occur in the reply.

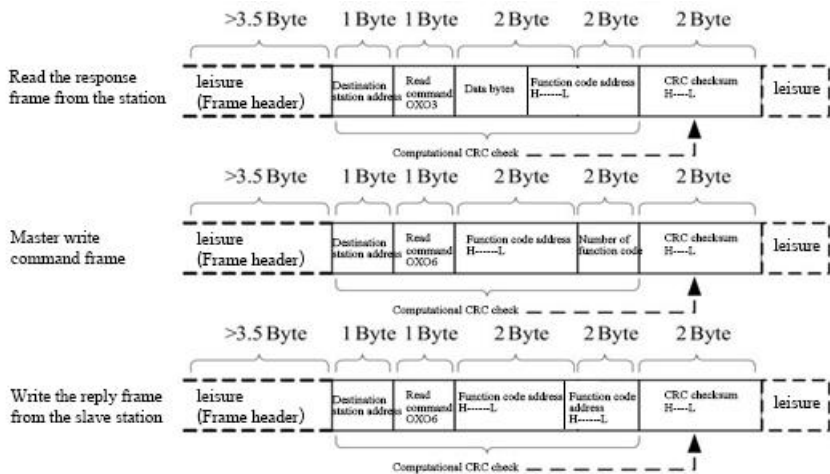

If the slave detects a communication frame error or fails to read or write due to other reasons, it will reply with an error frame.

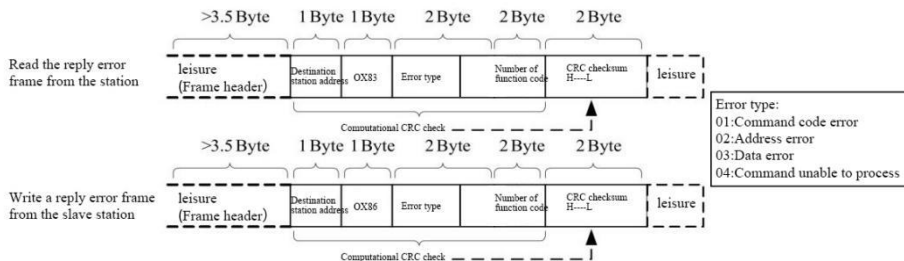

Data frame field description:

Frame header START	Idle greater than 3.5 character transmission time
Slave address ADR	Communication address range: 1 ~ 247; 0 = broadcast address
Command code CMD	03: Read slave parameters; 06: Write slave parameters
Function code address H	The internal parameter address of the frequency converter is expressed in hexadecimal; it is divided into functional code type and non-functional code type (such as running status parameters, running commands, etc.) parameters, etc. See address definition for details. When transmitting, the high byte comes first and the low byte comes last.
Function code address L	
Number of function codes H	The number of function codes read in this frame. If it is 1, it means reading 1 function code. When transmitting, the high

Number of function codes L	byte comes first and the low byte comes last. This protocol can only rewrite 1 function code at a time, and there is no such field.
Data H	The response data, or the data to be written, is transmitted with the high byte first and the low byte last.
Data L	
CRC CHK high bit	Detection value: CRC16 check value. When transmitting, the high byte comes first and the low byte comes last. For details on the calculation method, see the description of CRC check in this section.
CRC CHK low bit	
END	3.5 characters

CRC check method:

CRC (Cyclical Redundancy Check) uses the RTU frame format, and the message includes an error detection field based on the CRC method. The CRC field checks the contents of the entire message. The CRC field is two bytes containing a 16-bit binary value. It is calculated by the transmitting device and added to the message. The receiving device recalculates the CRC of the received message and compares it with the value in the received CRC field. If the two CRC values are not equal, there is an error in the transmission.

The CRC is first stored in 0xFFFF, and then a procedure is called to process the continuous 8-bit bytes in the message with the value in the current register. Only the 8Bit data in each character is valid for CRC, the start bit, stop bit and parity bit are invalid. During the CRC generation process, each 8-bit character is independently ORed (XOR) with the register content, the result is moved in the direction of the least significant bit, and the most significant bit is filled with 0s. The LSB is extracted and detected. If the LSB is 1, the register is XORED separately with the preset value. If the LSB is 0, it is not performed. The entire process is repeated 8 times. After the last bit (bit 8) is completed, the next 8-bit byte is XORED separately with the current value of the register. The value in the final register is the CRC value after all bytes in the message have been executed.

When the CRC is added to a message, the low byte is added first, then the high byte. The simple CRC function is as follows:

```
unsigned int crc_chk_value (unsigned char *data_value, unsigned char length)
{
    unsigned int crc_value=0xFFFF;
    int i;
    while (length--)
    {
        crc_value^=*data_value++;
        for (i=0;i<8;i++)
        {
            if (crc_value&0x0001)
            {
                crc_value= (crc_value>>1) ^0xa001;
            }
            else
            {
                crc_value=crc_value>>1;
            }
        }
    }
    return(crc_value);
}
```

4. Address definition of communication parameters

Read and write function code parameters (some function codes cannot be changed and are only for manufacturer use or monitoring):

Use function code group number and label as parameter address to express the rules:

High-order byte: F00 ~ FFF (F group), d00 (d group)

Low byte: 00 ~ FF

For example: if you want to range function code F00.20, the access address of the function code is expressed as 0xF014;

Notice:

Some parameters cannot be changed when the inverter is running; some parameters cannot be changed no matter what state the inverter is in; when changing function code parameters, pay attention to the parameter range, unit and related instructions.

Function code group number	Correspondence access address	Communication changes the function code address in RAM
F0 0 ~ Group F 15	0x A 000 ~ 0x AF FF	0x 4 000 ~ 0x 4F FF
Group F 16 ~ Group F 18	0x B 000 ~ 0x B2 FF	0x 50 00 ~ 0x 52 FF
F FF group	0x BF 00 ~ 0x BF FF	0x 5F 00 ~ 0x 5F FF
d0 0 group	0x7000~0x70FF	

Note that because EEPROM is frequently stored, the service life of EEPROM will be reduced. Therefore, some function codes do not need to be stored in communication mode. Just change the value in RAM.

5. Shutdown/operation parameters part:

Parameter address	Parameter Description	Parameter address	Parameter Description
1000H	* Communication setting value (decimal) -10000 ~ 10000	1010H	PID settings
1001H	Operating frequency	1011H	PID feedback
1002H	bus voltage	1012H	PLC steps
1003H	The output voltage	1013H	PULSE input pulse frequency, unit

			0.01kHz
1004H	Output current	1014H	Feedback speed, unit 0.1Hz
1005H	Output Power	1015H	remaining run time
1006H	Output torque	1016H	AI1 voltage before correction
1007H	Running speed	1017H	AI2 voltage before correction
1008H	Digital input terminal input flag	1018H	Panel potentiometer voltage before correction
1009H	Digital output terminal output flag	1019H	Line speed
100AH	AI1 voltage	101AH	Current power-on time
100BH	AI2 voltage	101BH	Current running time
100CH	Panel potentiometer voltage	101CH	PULSE input pulse frequency, unit 1Hz
100DH	Count value input	101DH	Communication settings
100EH	Length value input	101EH	actual feedback speed
100FH	load speed	101FH	Main frequency A display
-	-	1020H	Auxiliary frequency B display

Notice:

The communication setting value is a percentage of the relative value, 10000 corresponds to 100.00%, and -10000 corresponds to -100.00%.

Control command input to the inverter: (write only)

Command word address	Command function
2000H	0001: Forward running
	0002: Reverse operation
	0003: forward jog
	0004: Reverse jog
	0005: Free stop
	0006: Deceleration and stop
	0007: Fault reset

Read inverter status: (read only)

Status word address	Status word function
3000H	0001: Forward running
	0002: Reverse operation
	0003: shutdown

Parameter lock password verification: (if the return value is 8888H, it means the password verification is passed)

User password address	Enter password content
A F00H	*****

Digital output terminal control: (write only)

command address	Command content
2001H	BIT0: Y 1 output control BIT1: Y 2 output control

	BIT2: R 1 output control BIT3: R 2 output control
--	--

Analog output AO1 control: (write only)

command address	Command content
2002H	0~7FFF means 0%~100%

Analog output AO2 control: (write only)

command address	Command content
2003H	0~7FFF means 0%~100%

Pulse (PULSE) output control: (write only)

command address	Command content
2004H	0~7FFF means 0%~100%

5、Frequency converter fault description:

Inverter fault address	Frequency converter fault information
------------------------	---------------------------------------

8000H	0000: No fault 0001: Reserved 0002: Acceleration overcurrent 0003: Deceleration overcurrent 0004: Constant speed overcurrent 0005: Acceleration overvoltage 0006: Deceleration overvoltage 0007: Constant speed overvoltage 0008: Buffer resistor overload fault 0009: Undervoltage fault 000A: Frequency converter overload 000B: Motor overload 000C: Input phase loss 000D: Output phase loss 000E: Module overheating 000F: External fault 0010: Communication abnormality 0011: Reserved 0012: Current detection failure	0013: Motor tuning failure 0014: Reserved 0015: Parameter reading and writing abnormality 0016: Inverter hardware fault 0017: Reserved 0018: Reserved 0019: Reserved 001A: Running time reached 001B: User-defined fault 1 001C: User-defined fault 2 001D: Power-on time reached 001E: Load loss 001F: PID feedback is lost during operation 0028: Fast current limit timeout fault 002A: Speed deviation is too large 005C: Initial position error 0041: Photovoltaic water shortage detection failure
-------	---	--

6. The error code meaning of the slave's response to the exception message:

Error code address	error code	illustrate
8001H	01H	wrong password

	02H	Read and write command error
	03H	CRC check error
	04H	Invalid address
	05H	Invalid parameter
	06H	Parameter changes are invalid
	07H	System locked
	08H	Saving parameters

Appendix 2: Macro parameter setting instructions

Function macro definition	Setting parameters	Automatically modify parameter list	Debugging steps
One-to-two-work (1 variable frequency pump + 2 industrial frequency pumps) water supply mode 1	F00.00=1	F00.03=10; F14.02=11; F14.03=80; F14.04=2002; F14.05=11; F14.06=11; F07.00=53; F07.01=54; F07.02=55; F07.03=56; F07.04=57; F07.05=58; F08.02=42; F08.03=43; F08.04=44; F09.00=7.	Step1: Determine the sensor feedback type. AI1 and AI2 have factory default input voltage feedback signals. You can also select AI1 to input current feedback signals through jumper JP3; Step2: Terminal wiring. If the pressure gauge outputs 0~10V, connect the signal line of the pressure gauge to AI1, and connect the other two wires to +10V and GND; if the output is 0~20mA, short-circuit COM and GND. Connect the pressure gauge signal wire to AI1 and the other wire to 24V. For details on other terminal wiring, see Appendix 3 (Three-pump circulation soft water supply parameter description). Step3: Parameter initialization (F15.01=2);
Three-pump circulation soft start (3 frequency conversion)	F00.00=2		

pumps) water supply mode			<p>Step4: Set the sensor range (F16.09);</p> <p>Step5: Function macro selection (F00.00=1 or 2)</p> <p>Step6: Set the target pressure, which can be set through parameter F16.08, or through the up and down keys on the keyboard.</p>
One variable frequency pump and three industrial frequency pumps (1 variable frequency pump + 3 industrial frequency pumps) water supply mode	F00.00=3	F00.03=10; F14.02=11; F14.03=80; F14.04=2002; F14.05=11; F14.06=11; F08.02=42; F08.03=43; F08.04=44; F09.00=7.	<p>Step1: Determine the sensor feedback type. AI1 and AI2 have factory default input voltage feedback signals. You can also select AI1 to input current feedback signals through jumper JP3;</p> <p>Step2: Terminal wiring. If the pressure gauge outputs 0~10V, connect the signal line of the pressure gauge to AI1, and connect the other two wires to +10V and GND; if the output is 0~20mA, short-circuit COM and GND. Connect the pressure gauge signal wire to AI1 and the other wire to 24V.</p> <p>Step3: Parameter initialization (F14.12=2);</p> <p>Step4: Set the sensor range (F15.07);</p> <p>Step5: Function macro selection (F00.01=3, 4, 5, 6);</p> <p>Step6: Set the target pressure, which can be set through parameter F15.08 or through the up and down keys on the keyboard.</p> <p>Note: When F00.01=3, 4, 5, or 6, there is no need to connect the interlock circuit, just control the contactor through the main control board</p>
One-to-two-w ork(1 variable frequency pump+2 industrial frequency pumps) water supply mode	F00.00=4	F00.03=10; F14.02=11; F14.03=80; F14.04=2002; F14.05=11; F14.06=11; F08.02=42; F08.03=43; F09.00=7.	<p>Step4: Set the sensor range (F15.07);</p> <p>Step5: Function macro selection (F00.01=3, 4, 5, 6);</p> <p>Step6: Set the target pressure, which can be set through parameter F15.08 or through the up and down keys on the keyboard.</p> <p>Note: When F00.01=3, 4, 5, or 6, there is no need to connect the interlock circuit, just control the contactor through the main control board</p>

2			relay and Y terminal.
One-change-one-work (1 variable frequency pump + 1 industrial frequency pump) water supply mode	F00.00=5	F00.03=10; F14.02=11; F14.03=80; F14.04=2002; F14.05=11; F14.06=11; F08.02=42; F09.00=7;	
Single pump water supply (1 variable frequency pump) mode	F00.00=6	F00.03=10; F14.02=11; F14.03=80; F14.04=2002; F14.05=11; F14.06=11; F09.00=7.	
Photovoltaic water supply voltage tracking mode	F00.00=7	F00.03=11.	Step2: Parameter initialization (F15.02=2); F00.03=11. Step3: Function macro selection (F00.00=7, 8, 9). Note: For photovoltaic water supply, please refer to F16.10 ~ F16.26.
Photovoltaic water supply power and VF mode	F00.00=8		

Photovoltaic water supply power tracking SVC mode	F00.00=9		
---	----------	--	--

Appendix 3: Description of three-pump circulating soft water supply parameters

function code	name	Predetermined area	Factory settings	Change
F 00.00	Function macro definition	0: Universal mode 1: One variable frequency pump and two industrial frequency pumps (1 variable frequency pump + 2 industrial frequency pumps) water supply mode 1 2: Three-pump circulation soft start (3 frequency conversion pumps) water supply mode	0	×

F00 .02	Command source selection	1: Terminal operation command channel	0	×
F00 .03	Main frequency source selection	10: Multi-pump instructions	0	×
F07.00	Input terminal X1 function	53: Start/Stop 54: Run allowed 55: Interlock 1 56: Interlock 2 57: Interlock 3 58: PFC start/stop	53	×
F07 .01	Input terminal X2 function		54	×
F07.02	Input terminal X3 function		55	×
F07 .03	Input terminal X4 function		56	×
F07 .04	Input terminal X5 function		57	×
F07.05	Input terminal X6 function		58	×
F07 .06	Input terminal X7 function		0	×
F 08.02	Programmable relay R1 output		42 : Interlock 1 output 43 : Interlock 2 output 44 : Interlock 3 output	42
F 08.03	Programmable relay R2 output	43		×
F 08.04	Open collector Y1 output function selection	44		×
F 08.05	Open collector Y 2 output function	0		×

	selection			
F09.00	PID given source	0: F09.01 setting 1: AI1 2: AI2 3: Panel potentiometer 4: PULSE pulse setting (X7) 5: Communication given 6: Multi-segment command given	0	☆
F09.01	PID value given	0.0%~100.0%	50.0%	☆
F09.02	PID feedback source	0: AI1 1: AI2 2: Reserved 3: AI1-AI2 4: PULSE pulse setting (X7) 5: Communication reference 6: AI1+AI2 7: MAX(AI1 , AI2) 8: MIN(AI1 , AI2)	0	☆
F09.03	PID action direction	0: Positive effect 1: Reverse effect	0	☆
F09.04	PID given feedback range	0~65535	1000	☆

F09.05	Proportional gain Kp1	0.0~100.0	20.0	☆
F09.06	Integration time Ti1	0.01s~10.00s	2.00s	☆
F09.07	Differential time Td1	0.000s~10.000s	0.000s	☆
F09.08	PID inversion cutoff frequency	0.00 ~ maximum frequency	2.00Hz	☆
F09.09	PID deviation limit	0.0%~100.0%	0.0%	☆
F09.10	PID differential limiting	0.00%~100.00%	0.10%	☆
F09.11	PID given change time	0.00~650.00s	0.00s	☆
F09.12	PID feedback filter time	0.00~60.00s	0.00s	☆
F09.13	PID output filter time	0.00~60.00s	0.00s	☆
F09.26	PID feedback loss detection value	0.0%: No judgment, feedback loss 0.1% ~ 100.0%	0.0%	☆
F09.27	PID feedback loss detection time	0.0s~20.0s	0.0s	☆
F16.00	Terminal access and disconnection delay	0.0~6000.0s	0.1	☆
F16.01	Polling time	0.0~6000.0h	48.0	☆
F16.02	Reduce pump lower limit frequency	0.0~600.00HZ	35.00	☆
F16.03	Pump delay time	0.0~3600.0s	5.0	☆

F16.04	Decrease pump delay time	0.0~3600.0s	5.0	☆
F16.05	Water pump sleep wait time	0.0~3600.0s	2.0	☆
F16.06	Water pump wake-up waiting time	0.0~3600.0s	1.0	☆
F16.07	Water pump wakes up pressure points	(0.0~100.0%)* (F16.08)	80.0%	☆
F16.08	Preset pressure	0.00~F16.09 (MPa, Kg)	5.00	☆
F16.09	Pressure gauge range	0.00~100.00 (MPa, Kg)	10.00	☆

One. Instructions for use of one-to-two-work water supply mode 1 and three-pump circulating soft water supply mode :

- 1、 **One-change two-work water supply mode 1** means that the frequency converter only starts the first frequency conversion speed regulation, and the others are directly connected to the power grid.
- 2、 **The three-pump cyclic soft-start water supply mode** means that the frequency converter starts each pump and delays the connection to the power grid after starting; the one started first is connected to the power grid, and the one started later is used for speed regulation.

Two. Description of the use of external terminals and the working process of the addition and subtraction pump:

1、 Input terminals X1 ~ X6 have their functions fixed at the factory.

When F00.00 selects 1 or 2, the input terminals X1 ~ X6 have their water supply functions fixed.

2、Correspondence between X terminal, Y terminal and relay

After X3 is short-circuited to COM, it corresponds to No. 42 interlock 1 output in F08.02 ~ F08.05. For convenience of explanation, it is referred to as pump No. 1; after X4 is short-circuited to COM, it corresponds to No. 43 in F08.02 ~ F08.05. Interlock 2 output, referred to as pump No. 2; after X5 and COM are short-circuited, it corresponds to interlock 3 output No. 44 in F08.02 ~ F08.05, referred to as pump No. 3.

3、The difference between X1 and X6

X1 and _ .

4. Manually control the working process of starting and stopping the pump

After X1 and COM are short-circuited, the order of starting the pump is that the pump is put in first and starts first, and the pump is put in at the same time. For example, if only X5 is connected, only pump No. 3 will be turned on; if X4 and X5 are connected at the same time, only pump No. 2 will be turned on; if X3, X4 and X5 are connected at the same time, only pump No. 1 will be turned on.

5. Working process of multi-pump water supply mode

After X6 and COM are short-circuited, the order of starting the pump is that the pump is put in first and starts first, and the pumps put in at the same time start the smaller one for PID control.

(1) When F00.01=1 (one-to-two-work water supply mode 1 is valid), if all three water pumps are put into operation, after the system is powered on, the No. 1 pump will be connected first and the No. 1 frequency conversion pump will be started. When the operating frequency of the No. 1 variable frequency pump reaches 50Hz, the pump adding time (F16.03) is delayed. If the measured pressure does not reach the system set pressure, the No. 2 power frequency pump will be turned on. When the operating frequency of the No. 1 variable frequency pump resumes When reaching 50Hz, delay the pumping time (F16.03). If the measured pressure still does not reach the system set pressure, the No. 3 power frequency pump will be turned on. At this time, the No. 1 pump is in the frequency conversion working state. No. 2 and 3 Pump No. is in power frequency working state. If the measured pressure is greater than or equal to the system set pressure, the operating frequency of No. 1 variable frequency

pump drops to the lower limit frequency of pump reduction (F16.02). After the pump reduction delay (F16.04), the No. 3 power frequency pump will be disconnected. If the measured pressure is still greater than or equal to the system set pressure, and the operating frequency of the No. 1 variable frequency pump is less than or equal to the lower limit frequency of the pump reduction (F16.02), the No. 2 power frequency pump will be disconnected after the pump reduction delay (F16.04). In the end, only the No. 1 variable frequency pump is left to work.

(2) When F00.01=2 (the three-pump cycle soft start mode is valid), if all three water pumps are put into operation, after the system is powered on, pump No. 1 will be connected first and the frequency conversion operation of pump No. 1 will be started. When the frequency conversion of pump No. 1 is working at 50Hz, after adding the pump delay (F16.03), if the measured pressure cannot reach the system set pressure, disconnect the frequency conversion pump No. 1, and connect the frequency conversion pump No. 2 and the pump No. 1. Frequency pump, at this time, pump No. 1 switches from the frequency conversion state to the power frequency state, and pump No. 2 enters the frequency conversion state. When the frequency conversion of pump No. 2 is working at 50Hz, after adding the pump delay (F16.03), if the measured pressure still cannot reach the system set pressure, disconnect the frequency conversion pump No. 2 and connect the frequency conversion pump No. 3 and No. 2 Power frequency pump, at this time, pump No. 2 is converted from the variable frequency pump to work in the power frequency state, pump No. 3 is in the variable frequency working state, and pump No. 1 is still in the power frequency working state. When the operating frequency of pump No. 3 drops to the lower limit frequency of pump reduction (F16.02), after the pump reduction delay (F16.04), if the measured pressure is greater than or equal to the system set pressure, the power frequency pump No. 1 will be disconnected; when The working frequency of No. 3 pump is less than or equal to the lower limit frequency of pump reduction (F16.02). After the pump reduction delay (F16.04), if the measured pressure is still greater than or equal to the system set pressure, the No. 2 power frequency pump will be disconnected; in the end, only The frequency conversion pump No. 3 is left to work.

Note: If one-to-three is needed, all three pumps are put in; if one-to-two is needed, any two pumps are put in; if one to one is needed, one pump is put in at will; the one put in first will be started first. Enter the trumpet rules.

6、 Terminal access and disconnection delay

Since there is a delay in the connection and disconnection of the contactor terminal, the signal is not synchronized, and the terminal input disconnection delay (F 16. 00) needs to be adjusted .

7. X2 terminal description

X2 is the operation permission terminal. This terminal is connected to the normally closed point of the external fault relay. It is generally connected to external water shortage or high-voltage signal control. If there is no external fault detection, it needs to be short-circuited to COM.

Three. Application of STOP/RST key

1、 The factory default of F14.01 is 3, that is, the STOP/RST key is valid when the terminal control operation mode is in operation. If the machine is stopped using the keyboard, the X2 and X6 terminals must be reconnected or the power must be re-powered to operate normally.

2、 When F14.01=0, the STOP/RST key is invalid during terminal control and only resets the inverter fault. Under normal circumstances, F14.01 is set to 0 to prevent the keyboard from shutting down by misoperation. It is necessary to reconnect the X2 and X6 terminals or re- The electricity can work normally.

Four. Working process when water supply fails

1、 If an external fault occurs in the variable frequency pump, first stop the faulty pump, and then switch the larger industrial frequency pump to a variable frequency pump. For example, pumps No. 1, 2, and 3 are all turned on, No. 2 is a variable frequency pump, and No. 1 and No. 3 is a power frequency pump. If an inverter failure occurs, pump No. 2 will be stopped first, and then the power frequency of No. 3 will be switched to a variable frequency pump. No. 1 will continue to be a power frequency pump. If the external fault of pump No. 3 is resolved, it can be put into use normally. .

2. If an internal fault occurs in the frequency converter pump, all pumps will stop. After using the keyboard to reset

the frequency converter fault, it will return to normal working status.

Five. Function settings.

- 1、 To turn on the water supply function, you need to set F00.00 to option 1 or 2. Please refer to the manual for specific selections.
- 2、 To enable the PID function, you need to set F00.03=10, and then set the required PID parameters in group F09. See the manual for details.
3. Set F14.01 to 0, that is, the keyboard stop key is invalid.

Six. Water supply wiring diagram (refer to ABB's frequency converter ACS510 constant pressure water supply wiring diagram).

1、 Schematic diagram of open collector Y1 connected to relay:

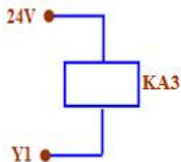

2. Introduction to wiring diagram symbols

In Figure 1 and Figure 2 below, L1 and L2 represent _____ supply. Indicates _____ terminal,

means normally open: _____ oil. Indicates relay _____ by R1 on the main board)



Normally open point, Indicates the normally open point of relay KA2 (controlled by R2 on the main board), and indicates the normally open point of relay KA3 (controlled by Y1 on the main board); KM1, KM2 and KM3 are the contactors that control the frequency conversion pumps No. 1, 2 and 3 respectively. KM11,

KM21 and KM31 are the contactors that control the power frequency pumps No. 1, 2 and 3 respectively. **(Note:**

Figures 1 and 2 below are just sketch logic diagrams. If

If a fault relay or indicator light is required, add it yourself)

3. Introduction to contactor interlocking and self-locking (shown in Figure 1)

When KM1 is connected, KM11, KM2 and KM3 cannot be connected.

When KM11 is connected, KM1 cannot be connected.

When KM2 is connected, KM21, KM1 and KM3 cannot be connected.

When KM21 is connected, KM2 cannot be connected.

When KM3 is connected, KM31, KM1 and KM2 cannot be connected.

When KM31 is connected, KM3 cannot be connected

Figure 1:

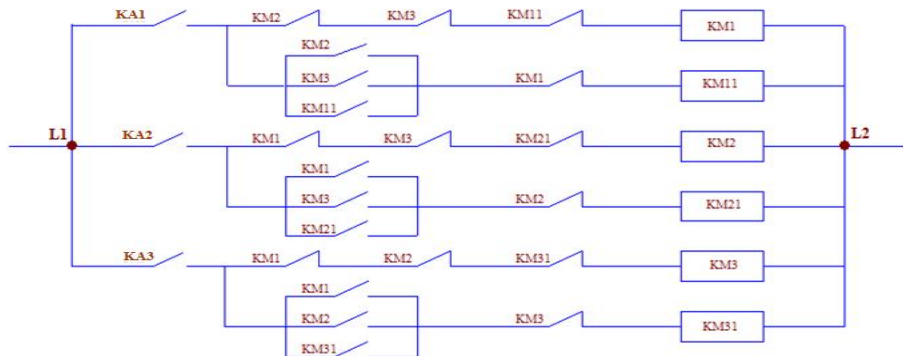
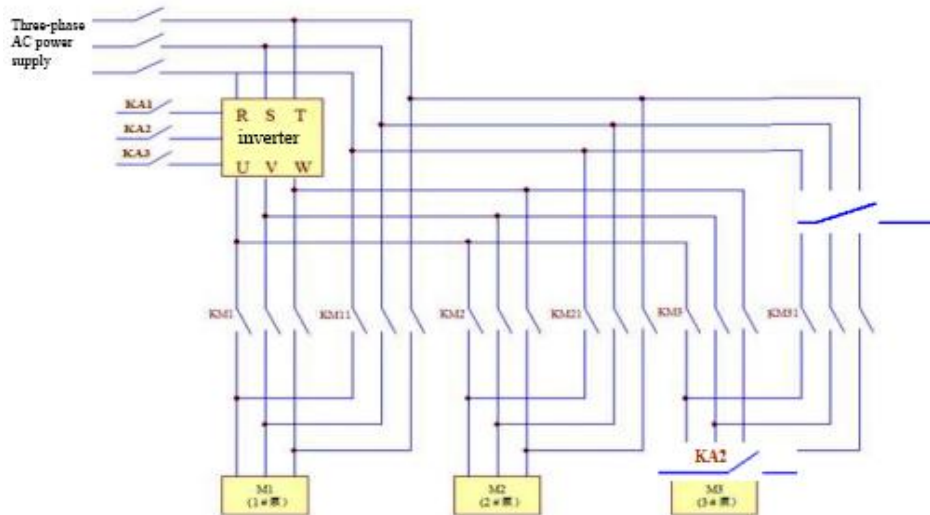

Figure 2:



Warranty Agreement

1 The warranty period of this product is 18 months (based on the barcode information on the fuselage). During the warranty period, if the product fails or is damaged under normal use in accordance with the instruction manual, our company will be responsible for free repairs.

2 During the warranty period, if damage occurs due to the following reasons, a certain repair fee will be charged:

- A. Machine damage caused by errors in use and unauthorized repairs and modifications;
- B. Machine damage caused by fire, flood, voltage abnormality, other natural disasters and secondary disasters;
- C. Hardware damage caused by human falling and transportation after purchase;
- D. Machine damage caused by not operating according to the user manual provided by our company;
- E. Failure and damage caused by obstacles other than the machine (such as external equipment factors);

3. When the product fails or is damaged, please fill in the various contents in the "Warranty Card" correctly and in detail.

4. Maintenance fees will be charged in accordance with our company's latest "Maintenance Price List".

5. This warranty card will not be reissued under normal circumstances. Please be sure to keep this card and show it to the maintenance personnel during warranty.

6. If you have any questions during the service process, please contact our agent or our company in time.

Warranty Card

Customer Information	Company address:	
	Company name:	Contact person:
	postal code:	Contact number:
	Product number:	
Product information	Body barcode (paste here):	

	Agent name:
accident details	(Maintenance time and content): Repair man:

Version number:V1.01